

Liquid Leak Detectors with Self-Contained Amplifier



Model HPQ-D□□

Built-in amplifier, liquid absorbing paper not needed, usable with various liquids. * For product details, contact one of our sales representatives or an Azbil dealer.

■ Acids or alkaline liquids, IPA (isopropyl alcohol), pure water, Fluorinert, Galden, etc.

■ Body and cable are protected by PFA.

■ Easy maintenance

*For explosion-proof applications, be sure to select a suitable fiber type.

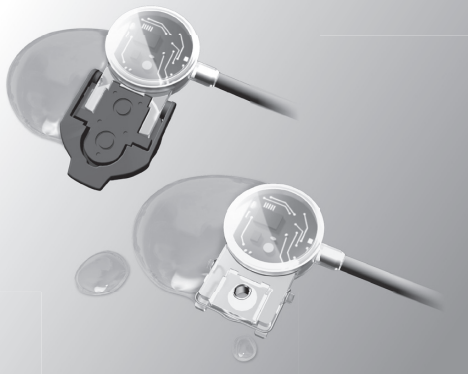

- PHOTOELECTRIC SENSORS & SWITCHES
- MEASUREMENT SENSORS
- PROXIMITY SWITCHES
- LIMIT SWITCHES
- SAFETY KEY SWITCHES
- FIBER-OPTIC
- WET PROCESSES SWITCHES AND FIBER UNITS
- SELF-CONTAINED
- TECHNICAL GUIDE

HPF-T032/T032E
HPF-T034/T034E

HPQ-T□

HPF-D027
HPF-D033

HPQ-D□□

HPQ-DP□□

HPF-D040

HPF-T047

FEATURES



Acids or alkaline liquids, IPA (isopropyl alcohol), pure water, Fluorinert, Galden, etc.

Notes: For explosion-proof applications, be sure to select a suitable fiber type. Fluorinert and Galden are registered trademarks of 3M and Solvay Solexis respectively.

Body and cable are protected by PFA.

PVC brackets are available for acidic or alkaline liquids. PFA (partially SUS) brackets are available for organic solvents.

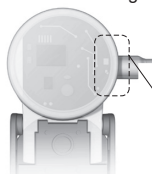

IP67

The cable exits the detect or through a PFA tube fused to the case. Therefore, leaking liquid cannot enter the detector.

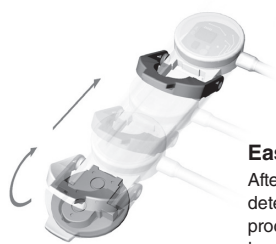

Easy maintenance

After leak detection, simply wipe the detector surface—a much easier process than with detection tape or a liquid-absorbing model.

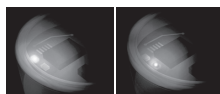

Operation indicator

Switch status can be checked from the body side.

Normal state (green LED lit)
Liquid leakage (red LED lit)

Suitable for export equipment

CE marking, UL certified.

Wide variety of output modes and types are available.

●NO/NC output ●NPN/PNP output

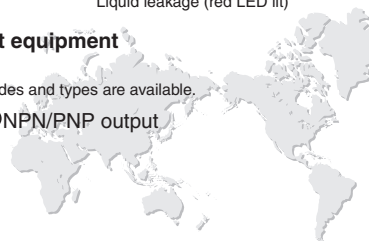

DETECTION PRINCIPLE

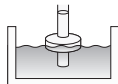
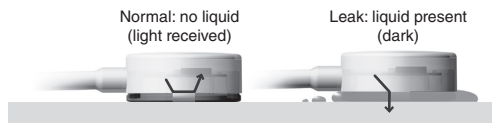



Install this switch in the pan by stud or adhesive (for PVC bracket type). Unlike the float type, switch does not require a concave surface underneath.

Note: This switch is not explosion-proof. Do not use it where the use of an explosion-proof product is specified.

CATALOG LISTING

●Body

Detection method & shape	Bracket material	Operation mode	Output mode	Catalog listing
 Retroreflective	PVC	NC	NC, NPN, PVC bracket type	HPQ-D11
		NC	NC, PNP, PVC bracket type	HPQ-D12
		NO	NO, NPN, PVC bracket type	HPQ-D13
 PFA	PFA	NC	NC, NPN, PFA bracket type	HPQ-D21
		NC	NC, PNP, PFA bracket type	HPQ-D22
		NO	NO, NPN, PFA bracket type	HPQ-D23

Accessory

Specifications	Catalog listing
PVC bracket (10 units)	HPQ-B01
PFA(SUS) bracket (10 units)	HPQ-B02

Notes: For HPQ-D11/12/21 models, a switch with 5 m cable (2 m PFA tube) is also available, specially produced for the U.S. market (-L05).
Normally open type: no UL certification.
Some UL-certified models are available. For details, contact Azbil Corporation.
S-mark-compliant models have special model numbers.
For details, contact one of our sales representatives.

SPECIFICATIONS

Catalog listing	HPQ-D11 / HPQ-D21	HPQ-D13 / HPQ-D23	HPQ-D12 / HPQ-D22
Detection method	Retroreflective		
Mounting surface	Polyvinyl chloride or stainless steel plate*		
Standard target object	Water*		
Light source	Infrared LED (peak emission wavelength 875 nm)		
Supply voltage	10.8 to 26.4 Vdc (ripple voltage 10 % max.)		
Current consumption	30 mA or less		
Operation mode	Normally ON, when leak detected OFF	Normally OFF, when leak detected ON	Normally ON, when leak detected OFF
Output mode	Open collector NPN		Open collector PNP
Control output	Switching current	50 mA or less (resistive load)	
	Output withstand voltage	30 Vdc	
	Residual voltage	1 V max. (at 50 mA switching current)	
Indicator	Normally green light ON, when leak detected orange light ON		
Operating temperature	-25 to +50 °C (without freezing)		
Storage temperature	-40 to +70 °C (without freezing)		
Operating humidity	30 to 85 % RH (without condensation)		
Dielectric strength	20 MΩ (at 500 Vdc)		
Withstand voltage	1,000 Vac, 50/60 Hz for 1 min between all electrically live metal and case		
Vibration resistance	10 to 55 Hz, 1.5 mm peak-to-peak amplitude, 2 h each in X, Y, and Z directions		
Shock resistance	500 m/s ² 3 times each in X, Y, and Z directions		
Protective structure	IP67 (IEC standard)		
Protection circuits	Built-in reverse connection protection, malfunction prevention at power ON (approx. 20 ms), output short-circuit protection		
Connection method	Preleaded, 2 m cable		
Material	Body: PFA. Cable: PFA coating. Mounting base: PVC or PFA (SUS)		
Mass	Approx. 55 g (main unit with 2 m cable)		

*Operation may be unstable depending on the color and condition of the mounting surface or the liquid. Before use, carefully check switch operation in the actual situation.

EXTERNAL DIMENSIONS

(unit: mm)

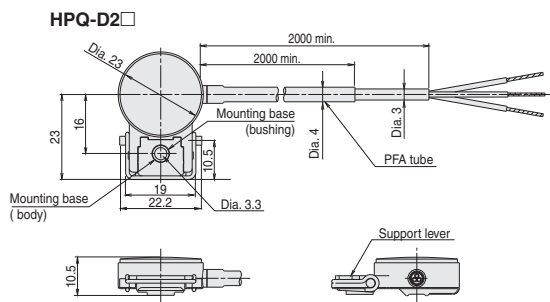
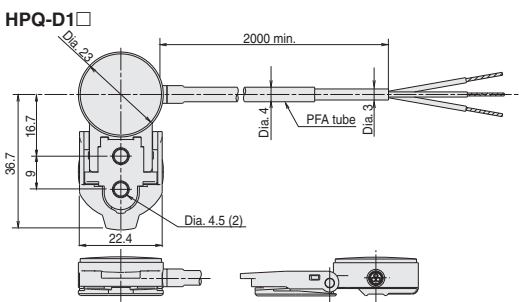

OUTPUT CIRCUIT DIAGRAM

HPQ-D□1(NPNtype)

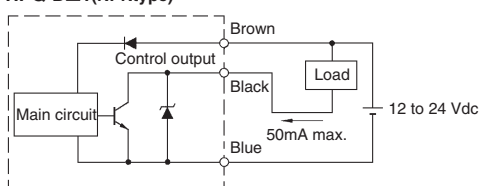

HPQ-D□2(PNPtype)

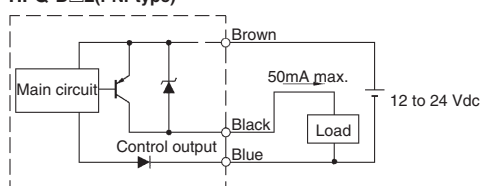

PRECAUTIONS FOR HANDLING

HPQ-D1□ (unit: mm)

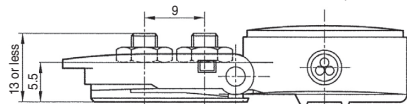

Installation

- Install this switch on a horizontal surface.
After attaching the mounting base, insert the switch into the mounting base and push the support lever on the body down to fix the switch.
- Screw mounting
In the case of a PVC mounting base, punch out the knock-out holes in the base, put two stud bolts with M4 thread that are stud-welded to a stainless steel (etc.) metal pan through the holes, and secure the switch with two M4 nuts. For a PFA mounting base, install in the same manner but with a single M3 stud bolt.
- Mounting with adhesive
The PVC type bracket can also be adhesive-mounted. If the surface on which the switch will be mounted is made of PVC (polyvinyl chloride), which is the same material as the mounting base, we recommend a monomer-based adhesive. However, regardless of the type of surface material, be sure to check the specifications of the adhesive to make sure that it is appropriate.

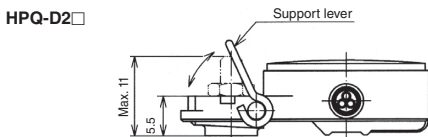

Before use, thoroughly read the "Precautions for use" and "Precautions for handling" in the Technical Guide on pages A-129 to A-144 as well as the instruction manual and product specification for this switch.