

# Smart Valve Positioner 300 Series

## Model AVP300/AVP301/AVP302

### OVERVIEW

Smart Valve Positioner 300 Series Models AVP300/AVP301/AVP302 are current-pneumatic smart valve positioners.

The 300 Series receives a DC current signal from control devices and controls pneumatic valves. In addition to this basic function, the 300 Series has communication capabilities, automatic configuration program, and self diagnostics functions that will greatly increase productivity and the efficiency of plant operation.

The model AVP301 has a valve travel transmitter function which transmits a 4–20 mA DC signal. The model AVP302 has a HART communication protocol.

### FEATURES

#### 1. Easy to use

##### • Auto setup

The auto-setup function is a fully-automatic configuration program which specifies the actuator and adjusts the zero and span of the valve. The program can be turned on simply from an external switch so that adjustments to the valve can be performed quickly and safely in hazardous areas.

#### 2. Single model for multiple specifications

The 300 Series' settings can be changed without replacing any parts. A single model can be modified to suit any application.

##### • Input range:

Configurable to any required range for split range

##### • Flow characteristic:

Linear, EQ%, Quick opening or custom user characteristics

##### • Actuator type:

Single or double acting actuator (optional reversing relay required)

#### 3. Valve diagnostic (Model AVP302 only)

Following parameters can be monitored by HART communicator or Control Valve Maintenance Support System "Valstaff".

- Stick Slip
- Total Stroke
- Travel Histogram
- Cycle Count
- Shut-Off Count
- Max. Travel Speed



#### 4. Positive seating

The positive seating function completely shuts off the valve if the input signal becomes lower than previously set. This in turn enhances the full shut-off capabilities of the valves.

#### 5. Easy maintenance

The electrical circuit section and air circuit section are completely separate, making the maintenance of the air circuit section at the work site easy. An Auto/Manual switch is standard equipment, so it is also easy to check the operation of the valve. (However, it is not available for the double-acting actuator.)

#### 6. Travel transmission

The model AVP301 transmits a 4–20 mA signal proportional to the valve travel. The valve travel can be monitored from the control room.

#### 7. Can be mounted on either a single or double-acting actuator.

On a double-acting actuator, a reversing relay is added at the output air pressure connector.

The wiring method differs depending on whether this device is used as a normal current-pneumatic positioner or as a positioner with a travel transmission function. When using this device as a normal current-pneumatic positioner, it is necessary only to connect the positioner to the host controller with an input signal cable (4–20 mA DC) as with previous models.

Figures 1 and 2 show the wiring diagrams.

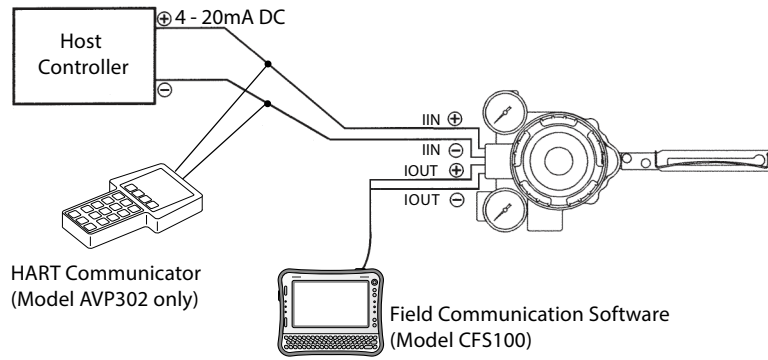

Figure 1. Current-pneumatic positioner (model AVP300/AVP302)

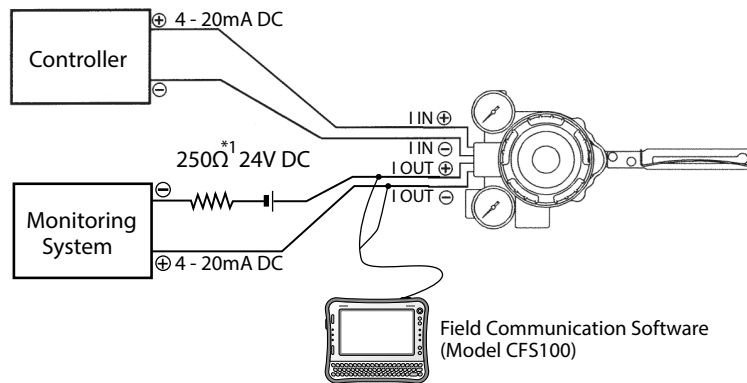

Figure 2. Positioner with travel transmission function (model AVP301)

\*1. For load resistance, refer to Figure 3.

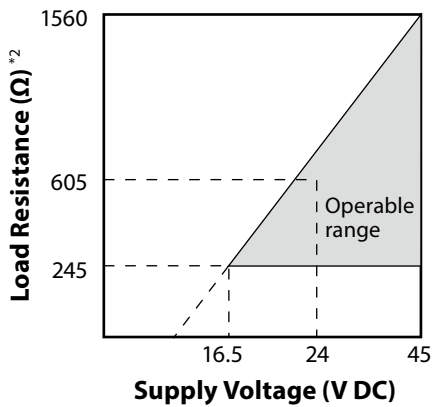

Figure 3. Supply voltage for travel transmission vs. load resistance characteristic

Note) Supply voltage shall be limited to 45 V DC

\*2. Load resistance = Resistance for Monitoring system + 250 Ω\*1 + Resistance of supply voltage\*1

Table 1. Actuator stroke and accuracy

Actuator	Stroke (mm)	Accuracy [% F.S.]
PA2	20	1.0
PA3, 4	20, 40	1.0
PA5	20, 40, 75	1.0
PSA1, 2	14.3, 20, 25	1.0
PSA3, 4	20, 38	1.0
HA1	6, 8, 10	3.0
	14.3, 25	1.0
HA2	10	3.0
	14.3, 25, 38	1.0
HA3	14.3	3.0
	25, 38, 50	1.0
HA4	14.3	3.0
	25, 38, 50, 75	1.0
VA5	25, 37.5, 50, 75, 100	1.0
VA6	14.3	3.0
PSA6, 7	25, 37.5, 50, 75, 100	1.0
HK1	10	3.0
PSK1	19	1.0
DAP560, 1000 1000X	14.3	3.0
	25 ~ 100	1.0
DAP1500, 1500X	14.3, 25	3.0
	38 ~ 100	1.0

**LIST OF FEATURES**

Item	Function
Desired input signal range	Any split-range value can be specified.
Forced fully open/closed	The control valve can be fully closed or opened securely when the desired percentage of input signal is reached.
Desired flow characteristics	The relationship between input signal and valve travel that is appropriate for the process can be defined by using a 16-point line graph.
Travel transmission (option)	Valve motion can be reliably monitored by transmitting the valve travel.

**FUNCTIONAL SPECIFICATIONS**

Item	Specification	
Applicable actuator	Pneumatic single and double acting, linear and rotary motion actuator	
Input signal	4–20 mA DC (Configurable to any required range for split range.) Minimum driving current: 3.85 mA *1	
Communication system	SFN communication (Model AVP300/301/302) HART6 communication (Model AVP302)	
Output signal	4–20 mA DC (Travel transmission) *2	
Input resistance	300 Ω typically / 20 mA DC (Model AVP300/AVP301 Waterproof, Flameproof) 350 Ω typically / 20 mA DC (Model AVP300/AVP301 FM/CCC/ATEX/CNS Intrinsically safe) 400 Ω typically / 20 mA DC (Model AVP302)	
Lightning protection	Peak value of voltage surge: 12 kV Peak value of current surge: 1000 A	
Flow characteristics	Linear, Equal percentage, Quick opening Custom user characteristics (16 points)	
Manual operation	Auto/Manual external switch (Not available for double acting actuator)	
Supply air pressure	140 to 700 kPa	
Air consumption	For single acting actuator	4 L/min (N) or less: with steady supply air pressure of 140 kPa {1.4 kgf/cm <sup>2</sup> } and output of 50 % 5 L/min (N) or less: with steady supply air pressure of 280 kPa {2.8 kgf/cm <sup>2</sup> } and output of 50 % 6 L/min (N) or less: with steady supply air pressure of 500 kPa {5.0 kgf/cm <sup>2</sup> } and output of 50 %
	For double acting actuator	10 L/min (N) or less: with steady supply air pressure of 400 kPa {4.0 kgf/cm <sup>2</sup> }
Output balanced pressure	55±5 % for double acting actuator only (without a load, and when output air pressure is balanced)	
Maximum air deliver flowrate	For single acting actuator	110 L/min (N) maximum at 140 kPa {1.4 kgf/cm <sup>2</sup> }
	For double acting actuator	250 L/min (N) maximum at 400 kPa {4.0 kgf/cm <sup>2</sup> }
Air connections	Rc1/4 or 1/4NPT internal thread	
Electrical connections	G1/2, 1/2NPT or M20×1.5 internal thread	
Ambient temperature limits	General, FM Explosionproof, FM Intrinsically safe models : -40 to +80 °C TIIS / KCs (main unit model number "S") Flameproof models : -20 to +55 °C ATEX / KCs (main unit model number "H") / IECEx / CCC / CNS Flameproof models : -40 to +75 °C ATEX / CCC / CNS Intrinsically safe models : -40 to +60 °C	
Ambient humidity limits	10 to 90 %RH	
Vibration characteristics	20 m/s <sup>2</sup> , 5 to 400 Hz (with standard mounting kit on Azbil Corporation's HA actuator)	
Finish	Standard finish and silver finish: Baked acrylic Corrosion proof finish: Baked Urethane	
Color	Silver/Dark Gray or Dark Blue	
Material	Cast aluminum	
Weight	2.5 kg. (3.2 kg with a pressure regulator with filter model KZ03) (If combined with a reversing relay for a double-acting actuator, add 0.3 kg to the weight.)	
Performance	Accuracy	±1.0% F.S.(±2.5 % with user-defined flow characteristics) ±3.0 % FS if the feedback lever angle is outside the ±4° to ±20° range (refer to Table 1 of 2nd page) There is an additional 0.5 % FS (input error) if 4 mA ≤ input signal span < 8 mA
	Travel transmission accuracy *2	±1 %F.S.(±2.5 % with user-defined flow characteristics)
	Stroke coverage	14.3 to 100 mm Stroke (Feedback Lever Angle ±4° to ±20°)
Enclosure classification	JIS C0920 watertight, NEMA type 4X, IP66	

Item	Specification	
Structure	TIIS Flameproof	Ex d IIC T6 Gb
	KCs Flameproof	Ex d IIC T6 Flameproof cable gland and Stopping plug must be KCs Ex d IIC approved.
	FM Explosionproof	Explosionproof: Class I, Division 1, Group A, B, C, D Dust-ignition: Class II, Division 1, Group E, F, G Suitable: Class III, Division 1 Flameproof: Class I, Zone 1, AEx d IIC T6 at $T_{amb} < 80\text{ }^{\circ}\text{C}$ NEMA Type 4X The wiring conduit cable gland and electrical wiring must be compliant with the National Electrical Code (NEC).
	FM Intrinsically safe	Intrinsically safe: Class I, II, III, Division 1, Group A, B, C, D, E, F, G, T4 Intrinsically safe: Class I, Zone 0, AEx ia IIC T4 Nonincendive: Class I, Division 2, Group A, B, C, D, T5 Suitable: Class II, III, Division 2, Groups F, G, T4 NEMA Type 4X, IP66 The barriers should be FM recognized types and comply with the following conditions as follows: Input circuit(terminals $\pm$ IIN) Model AVP300/AVP301: $12.02 \leq V_{max} \leq 30\text{ V}$ , $I_{max} = 100\text{ mA}$ , $P_i = 1\text{ W}$ , $C_i = 18.26\text{ nF}$ , $L_i = 0.22\text{ mH}$ Model AVP302: $12.02 \leq V_{max} \leq 30\text{ V}$ , $I_{max} = 100\text{ mA}$ , $P_i = 1\text{ W}$ , $C_i = 41\text{ nF}$ , $L_i = 0.22\text{ mH}$ Output circuit(terminals $\pm$ OUT) Model AVP301: $V_{max} = 30\text{ V}$ , $I_{max} = 100\text{ mA}$ , $P_i = 1\text{ W}$ , $C_i = 22\text{ nF}$ , $L_i = 0.22\text{ mH}$ Installation should comply with NEC.
	ATEX Flameproof	II 2 G Ex db IIC T6 Gb $-40^{\circ}\text{C} \leq T_{amb} \leq +75^{\circ}\text{C}$ IEC IP66 Flameproof cable gland must be ATEX Ex db IIC approved. <i>Note: IP66 waterproof and dust-proof performance can be assured by installing an appropriate cable gland.</i>
	ATEX Intrinsically safe	II 1 G Ex ia IIC T4 Ga; $-40^{\circ}\text{C} \leq T_{amb} \leq +60^{\circ}\text{C}$ II 1 D Ex ia IIIC T <sub>200</sub> 135 $^{\circ}\text{C}$ Da; $-40^{\circ}\text{C} \leq T_{amb} \leq +50^{\circ}\text{C}$ IEC IP66 The barriers should be ATEX certified types and comply with the following condition as follows: Input circuit (terminals $\pm$ IIN) Model AVP300/AVP301: $U_i = 30\text{ V}$ , $I_i = 100\text{ mA}$ (resistively limited), $P_i = 1\text{ W}$ , $C_i = 5\text{ nF}$ , $L_i = 0.22\text{ mH}$ Model AVP302: $U_i = 30\text{ V}$ , $I_i = 100\text{ mA}$ (resistively limited), $P_i = 1\text{ W}$ , $C_i = 41\text{ nF}$ , $L_i = 0.22\text{ mH}$ Output circuit (terminals $\pm$ IOUT) Model AVP301: $U_i = 30\text{ V}$ , $I_i = 100\text{ mA}$ (resistively limited), $P_i = 1\text{ W}$ , $C_i = 22\text{ nF}$ , $L_i = 0.22\text{ mH}$
	CCC Flameproof	Ex db IIC T6 Gb Flameproof cable gland must be CCC Ex d IIC approved.
	CCC Intrinsically safe	Ex ia IIC T4 Ga; $-40^{\circ}\text{C} \leq T_{amb} \leq +60^{\circ}\text{C}$ Ex ia IIIC T <sub>200</sub> 135 $^{\circ}\text{C}$ Da; $-40^{\circ}\text{C} \leq T_{amb} \leq +50^{\circ}\text{C}$ The barriers should be CCC certified types and comply with the following condition as follows: Input circuit (terminals $\pm$ IIN) Model AVP300/AVP301: $U_i = 30\text{ V}$ , $I_i = 100\text{ mA}$ , $P_i = 1\text{ W}$ , $C_i = 5\text{ nF}$ , $L_i = 0.22\text{ mH}$ Model AVP302: $U_i = 30\text{ V}$ , $I_i = 100\text{ mA}$ , $P_i = 1\text{ W}$ , $C_i = 41\text{ nF}$ , $L_i = 0.22\text{ mH}$ Output circuit (terminals $\pm$ IOUT) Model AVP301: $U_i = 30\text{ V}$ , $I_i = 100\text{ mA}$ , $P_i = 1\text{ W}$ , $C_i = 22\text{ nF}$ , $L_i = 0.22\text{ mH}$
	Combination of CCC Flameproof and Intrinsically safe	When used as CCC Flameproof, it complies CCC Flameproof approval as above. When used as CCC Intrinsically safe, it complies CCC Intrinsically safe approval as above.
	IECEx Flameproof	Ex db IIC T6 Gb IEC IP66 Flameproof cable gland must be IECEx Ex db IIC approved. <i>Note: IP66 waterproof and dust-proof performance can be assured by installing an appropriate cable gland.</i>

Item	Specification	
Structure	CNS Flameproof	Ex db IIC T6 Gb IEC IP66 Flameproof cable gland must be CNS Ex db IIC approved. <i>Note: IP66 waterproof and dust-proof performance can be assured by installing an appropriate cable gland.</i>
	CNS Intrinsically safe	Ex ia IIC T4 Ga IEC IP66 The barriers should be CNS certified types and comply with the following condition as follows: Input circuit (terminals $\pm$ IIN) Model AVP300/AVP301: $U_i=30$ V, $I_i=100$ mA, $P_i=1$ W, $C_i=5$ nF, $L_i=0.22$ mH Model AVP302: $U_i=30$ V, $I_i=100$ mA, $P_i=1$ W, $C_i=41$ nF, $L_i=0.22$ mH Output circuit (terminals $\pm$ IOUT) Model AVP301: $U_i=30$ V, $I_i=100$ mA, $P_i=1$ W, $C_i=22$ nF, $L_i=0.22$ mH
CE Marking	EN 61326-1: 2013 (EMC), EN IEC 63000:2018 (RoHS)	
Configuration tools	Field Communication Software (Model CFS100)	

\*1. In case of model AVP301 when signal input is less than 3.85 mA, output current will be burnout(up or down (indefinite)).

\*2. This applies only to positioners with travel transmission (model AVP301). In this case, a power supply circuit for travel transmission is required.

Note: Depending on the inner diameter and length of the air pipe, automatic setup might not be sufficient to realize the optimum operation. In such a case, please specify the relevant parameters.

### Conditions of supply air (JIS C1805-1 (2001))

Item	Specification
Particles	Maximum diameter 3 $\mu$ m
Oil mist	Less than 1 ppm at mass
Humidity of the air supply	The dew point should be at least 10°C lower than the temperature of this device.

To meet the above specifications for instrument air, install the air purification devices listed below properly in the specified installation location.

### Examples of air purification devices

Installation	Air purification device	SMC corporation	CKD corporation
Compressor outlet or main line	Line filter	AFF series	AF series
	Mist separator	AM series	
Terminal device	Mist separator	AM150 or AM250 series	M3000S type

### Individual specifications

Following shows default and optional settings of each configurable parameter of AVP.

Unless otherwise specified, the Smart Valve Positioner will be shipped in the following configuration.

Input control signal	4 to 20 mA	The minimal span for custom range = 4 mA
Output characteristic *1	Liner	EQ or QO can be ordered or set by user.
Valve action *2	Direct (Push down to close)	Reverse (Push down to open) can be ordered or set by use
Output signal for position transmission	4 to 20 mA	DE also selectable

\*1. Refer to the following when selecting the input/output characteristics.

\*2. Positioner action differs from actuator and control valve action, so be careful in selecting the positioner's action.

**Figure 4. Input-output characterization**

#### Selection of input characterization

The flow characteristic of a control valve is set by selecting the valve plug characteristic, and the input-output characteristics of the positioner must be specified as linear. However, if the valve plug flow characteristic, which depends on the control valve's shape and structure, does not meet requirements, you can correct the overall flow characteristic of the control valve by specifying "equal percentage" or "quick opening" for the input-output characteristics of the positioner, as shown in Table 2.

**Table 2. Control valve flow characteristics correction by the positioner**

Characteristic of valve plug	Input-output characterization of positioner	Overall flow characteristic of control valve
Linear	Quick opening	Quick opening
Linear	EQ%	EQ%
EQ%	Quick opening	Linear

*Note: If the valve plug characteristic is "quick opening," the overall flow characteristic of the control valve cannot be linear even if "equal percentage" is set for the positioner's input-output characteristics. (This is because when the valve plug characteristic is "quick opening," the control valve works as an ON/OFF valve and it is difficult to correct its characteristics by changing the setting of the positioner.)*

## MODEL SELECTION

### Basic model number

		(1)	(2)	(3)	(4)	(5)
AVP300	Analog signal (4 to 20 mA DC) without position transmission					
AVP301	Analog signal (4 to 20 mA DC) with position transmission					
AVP302	Analog signal (4 to 20 mA DC) HART protocol					
		(Air pipes, conduit connections)				
(1) Main unit model number	Water-proof	(Rc 1/4, G1/2)	X			
	Water-proof	(1/4 NPT, 1/2 NPT)	P			
	Water-proof	(1/4 NPT, M20×1.5)	Q			
	TIIS Flameproof with one flameproof cable gland *1	(Rc 1/4, G1/2)	E			
	KCs Flameproof	(1/4 NPT, 1/2 NPT)	H			
	FM Explosionproof and Flameproof	(1/4 NPT, 1/2 NPT)	F			
	FM Intrinsically safe	(1/4 NPT, 1/2 NPT)	M			
	FM Intrinsically safe	(1/4 NPT, G1/2)	6			
	ATEX Flameproof	(1/4 NPT, M20×1.5)	C			
	ATEX Flameproof	(1/4 NPT, 1/2 NPT)	Y			
	ATEX Intrinsically safe	(1/4 NPT, M20×1.5)	L			
	ATEX Intrinsically safe	(1/4 NPT, 1/2 NPT)	U			
	ATEX Intrinsically safe	(Rc 1/4, G1/2)	V			
	CCC Flameproof	(1/4 NPT, 1/2 NPT)	B			
	CCC Flameproof	(1/4 NPT, M20×1.5)	N			
	CCC Intrinsically safe and Flameproof	(1/4 NPT, 1/2 NPT)	R			
	CCC Intrinsically safe and Flameproof	(1/4 NPT, M20×1.5)	W			
	IECEX Flameproof	(1/4 NPT, 1/2 NPT)	J			
	IECEX Flameproof	(1/4 NPT, M20×1.5)	G			
	CNS Flameproof	(1/4 NPT, 1/2 NPT)	D			
CNS Flameproof	(1/4 NPT, M20×1.5)	I				
CNS Intrinsically safe	(1/4 NPT, M20×1.5)	Z				
CNS Intrinsically safe	(1/4 NPT, 1/2 NPT)	0				
(2) Finish	Standard (Silver/Dark Gray)		A			
	Corrosion proof (Silver/Dark Gray)		C			
	Standard (Dark Blue)		S			
	Corrosion proof (Dark Blue)		B			
	Silver finish		D			
(3) Positioner action *2	Direct Action (standard) - Air pressure increases with Control signal increase			D		
	Reverse Action (reverse positioning) Airpressure decreases with Control signal increase			R		
		(Pressure gauge scale, Max regulator setting)				
(4) Supply air pressure type	140 ≤ Ps ≤ 150 kPa	(200 kPa, 400 kPa)				1
	150 < Ps ≤ 300 kPa	(400 kPa, 400 kPa)				2
	300 < Ps ≤ 400 kPa	(600 kPa, 400 kPa)				3
	400 < Ps ≤ 450 kPa	(600 kPa, 700 kPa)				4
	450 < Ps ≤ 700 kPa	(1000 kPa, 700 kPa)				5
(5) Pressure units	kPa					A
	(kgf/cm <sup>2</sup> ) *3					(B)
	MPa					C
	bar					D
	(psi) *3					(E)

\*1. If you need two flameproof cable glands for model AVP301, select option code "B".

\*2. When the input signal (power) is shut off, select direct action to make the output air pressure of this device zero, and reverse action to make the output at the maximum air pressure (supply air pressure). Positioner action differs from actuator and control valve action, so be careful in selecting the positioner's action.

If double acting actuator are using, not available code "R".

\*3. Items in parentheses are for overseas use. As such, they cannot be used in Japan.

Accessory Selection		(6)	(7)	(8)	(9)	(10)	
(6) Regulator with filter	Without regulator	X					
	With model KZ03 regulator (attached to main unit) *1	1					
	With model KZ03 regulator (with mounting plate for separate installation)	2					
(7) Mounting bracket material (mounting plate/bolts)	No mounting plate		X				
	SUS304 / SUS304		D				
(8)(9) Mounting bracket for attachment to actuator *9	No mounting plate				XX		
	PA2, 3				YH		
	PSA1, PSA2, PSK1				YS		
	PA4, 5, New model PSA3, 4 (produced after 2000), VA1 to 3 (produced after May. '83)				YQ		
	PSA3, PSA4 for existing valves produced on/before 1999				YY		
	PSA6, VA4 to 6 (produced after May. '83)				YL		
	PSA7				Y8		
	HA1				YA		
	HA2, HA3, HL2, HL3				YT		
	HA4, HL4				YN		
	HK1, VM1 *2				YK		
	VM12 for model VSP *3				YB		
	VR1				YV		
	VR2, VR3				YR		
	VR3H				Y6		
	RSA1				YF		
	RSA2				YU		
	GOM 83S, GOM 84S, GOM 103S				YG		
	GOM 124S				YM		
	VA1 to 3 (produced before Apr. '83, former model Motion Connector), 800-1, 2, 3 *4				YW		
	VA4, 5 (produced before Apr. '83, former model Motion Connector), 800-4, 5 *4				YJ		
	Actuators of other manufacturers				See Table 3		
	Double-acting actuators	VP5, 6 *5				Y1	
		VP7 *5				Y7	
		SLOP560, 1000, 1000X *5 (stroke : 100mm max)				Y2	
		SLOP1500, 1500X *5 (stroke : 100mm max)				Y3	
		DAP560, 1000, 1000X *5 (stroke : 100mm max)				Y4	
		DAP1500, 1500X *5 (stroke : 100mm max)				Y5	
		DAP560 (VFR : 8 to 12B)				LA	
		DAP560 (VFR : 14B, 16B)				LB	
		DAP560 (VDC, VDN, VST : 16B)				LC	
		DAP1000, 1000X (VDC, VDN, VST : 16B)				LD	
		DAP1500, 1500X (VDC, VDN, VST : 16B)				LE	
GOM64LM, 84LM (springless, vertical, double acting) *6					GA		
GOM64LM, 84LM (springless, vertical, double acting) *7					GB		
GOM124LM (springless, vertical, double acting) *6					GC		
GOM124LM (springless, vertical, double acting) *7					GD		
Actuators of other manufacturers				See Table 4			
(10) Option	None					X	
	Explosion-proof universal elbow (SUS304 G1/2) 1 piece					A	
	Flameproof cable gland (G1/2) 1 piece (TIIS flameproof for Model AVP301 only)					B	
	Explosion-proof universal elbow (SUS304 G1/2) 2 pieces					C	
	Mounting screw Unify (5/16-18UNC) (Electrical conduit connection only supports 1/2NPT)					T	
	Double-acting reversing relay *8					W	

\*1. Select the code "1" only when the direction of drain of the pressure regulator with filter on the control valve is downward(ground).  
 \*2. In case "VM" type actuator is required following conditions, 1. select model "VCT" for the body, 2. the existing positioner should be HEP or VPE, 3. yoke should be model HK. If another spec. is required, contact your sales representative.  
 \*3. Additional support bracket is required.  
 \*4. Consult with sales representative in case of no mounting hole on the side of valve yoke.  
 \*5. In case of double acting actuator, a reversing relay unit required.  
 \*6. In case of valve body is not butterfly valve of Azbil Corporation.  
 \*7. In case of valve body is butterfly valve of Azbil Corporation.  
 \*8. If reverse action is selected for positioner action, this option cannot be selected.  
 \*9. Accuracy differs depending on the actuator stroke (see Table 1).

**Table 3. Mounting bracket for single acting actuator**

(8)(9) Mounting bracket for pneumatic actuator	Code
Motoyama Mfg. 2800 series 240, 280, 330, Nihon Koso A100 series 270, 320 *	TA
Motoyama Mfg. 2800 series 400, 500S, 500L, Nihon Koso A100 series 400, 500 *	TB
Motoyama Mfg. 2800 series 650S, 650L*	TC
Motoyama Mfg. 2800 series 240, 280, 330 (with side manual handle)	TD
Motoyama Mfg. 2800 series 400, 500S, 500L (with side manual handle)	TE
Motoyama Mfg. 2800 series 650S, 650L (with side manual handle)	TF
Motoyama Mfg. 3800 series (multi-spring type) N24, N28, N33S	TJ
Motoyama Mfg. 2922 series (Gyrol-I) G.R.I 280H, 330H, 400HS, 400H, 500H	TL
Motoyama Mfg. 3993 series (Gyrol-II) 2911-1M series 280, 330, 400	TG
Nihon Koso 5100L series 240, 280 *	TP
Nihon KOSO 5100L Series 330, 400, 5200LA Series 400 *	TQ
Nihon Koso 5200L series 218, 270, 350 *	TR
NIHON KOSO 5200LA SERIES 450 *	TV
Masoneilan 37, 38 series #9, #11 *	MA
Masoneilan 37, 38 series #13 *	MB
Masoneilan 37, 38 Series #13 (w/Side handle)	ME
Masoneilan 37, 38 series #15, #18 *	MC
Masoneilan 37, 38 series #15, #18 (with side manual handle)	MF
Masoneilan type 35002 series Camflex II #41/2, #6, (Valve size 1 inch - 4 inches)	MG
Masoneilan type 35002 Camflex II #7 (Valve size 6 inches - 12 inches)	MH
Masoneilan 37, 38 Series #11 *	MJ
Masoneilan 82, 83 Series #13 (w/Side handle w/o Side handle)	MK
Masoneilan 82, 83 Series #15 *	ML
Masoneilan 82, 83 Series #18 *	MM
Fisher 657, 667 series size 40	FB
Fisher 657, 667 series size 45, 50	FC

(8)(9) Mounting bracket for pneumatic actuator	Code
Emerson Valves & Controls Japan (Formerly Kitamura Valve) AK09S, 12S, 15S	KA
Emerson Valves & Controls Japan (Formerly Kitamura Valve) AG06S, AGN06S	KG
Emerson Valves & Controls Japan (Formerly Kitamura Valve) AG09S, AGN09S	KH
Emerson Valves & Controls Japan (Formerly Kitamura Valve) AG13S, AGN13S	KJ
Emerson Valves & Controls Japan (Formerly Kitamura Valve) AW13S	KV
Emerson Valves & Controls Japan (Formerly Kitamura Valve) AW17S	KW
Emerson Valves & Controls Japan (Formerly Kitamura Valve) AW20S	KT
Emerson Valves & Controls Japan (Formerly Kitamura Valve) AW28S	KD
KITZ B Series BS-2, BSW-2	B2
KITZ B Series BS-3, BSW-3	B3
KITZ B Series BS-4, BSW-4	B4
KITZ B Series BS-5, BSW-5	B5
KITZ B Series BS-6, BSW-6	B6
Emerson(EL-O-MATIC) E25, 40, 65, 100, 200, 350	RA
Emerson(EL-O-MATIC) E600, 950, 1600, P2500, P4000	RB
Hisaka Mfg. TS-1	H1
Hisaka Mfg. TS-2	H2
Hisaka Mfg. TS-3	H3
Hisaka Mfg. TS-4, Old type TS-5(Mounting screw M8)	H4
Hisaka Mfg. New TS-5(Mounting screw M10), TS-6	H6
TOMOE Valve Z Series Z-06S, 08S, 11S, 13S	EA
TOMOE Valve T-matic 3Q-1, 2, 3, 4	E3
Nakakita Seisakusho Co. dia. 420, 430, 460, 480	JB

\* Select in the case of without manual handle or with manual handle mounted on top of the actuators.

**Table 4. Mounting bracket for double acting actuator**

(8)(9) Mounting bracket for pneumatic actuator	Code
Emerson Valves & Controls Japan (Formerly Kitamura Valve) AK09, AK12, AK15 *	KA
Emerson Valves & Controls Japan (Formerly Kitamura Valve) AG06, AGN06 *	KG
Emerson Valves & Controls Japan (Formerly Kitamura Valve) AG09, AGN09 *	KH
Emerson Valves & Controls Japan (Formerly Kitamura Valve) AG13, AGN13 *	KJ
Emerson Valves & Controls Japan (Formerly Kitamura Valve) AW13 *	KV
Emerson Valves & Controls Japan (Formerly Kitamura Valve) AW17 *	KW
Emerson Valves & Controls Japan (Formerly Kitamura Valve) AW17-HG (w/manual gear handle) *	KB
Emerson Valves & Controls Japan (Formerly Kitamura Valve) AW20 *	KT
Emerson Valves & Controls Japan (Formerly Kitamura Valve) AW20-HG (w/manual gear handle) *	KC
Emerson Valves & Controls Japan (Formerly Kitamura Valve) AW28 *	KD
Emerson Valves & Controls Japan (Formerly Kitamura Valve) AW28-HG (w/manual gear handle) *	KE
KITZ B series B-2 *	B2
KITZ B series B-3 *	B3
KITZ B series B-4 *	B4
KITZ B series B-5 *	B5
KITZ B series B-6 *	B6

(8)(9) Mounting bracket for pneumatic actuator	Code
Emerson (EL-O-MATIC) E25, 40, 65, 100, 200, 350 *	RA
Emerson(EL-O-MATIC) E600, 950, 1600, P2500, P4000 *	RB
Hisaka Mfg. TD1	H1
Hisaka Mfg. TD2	H2
Hisaka Mfg. TD3	H3
Hisaka Mfg. TD4, Old type TD5 (Mounting screw M8)	H4
Hisaka Mfg. New TD5 (Mounting screw M10), TD6	H6
TOMOE Valve Z Series Z-06, 08, 11, 13 *	EA
TOMOE Valve T-matic 3I-1, 2, 3, 4 *	E3
T.V. Valve AT4-80 *	V1
T.V. Valve AT4-100 *	V2
T.V. Valve AT4-120 *	V3
T.V. Valve AT4-150 *	V4
T.V. Valve AT4-180 *	V5
Nihon KOSO AT550, AT600, AT650, AT700 *	TW

\* In case of double acting actuator, a reversing relay unit required.

**DIMENSIONS**

**For single acting actuator without pressure regulator**

[Unit: mm]

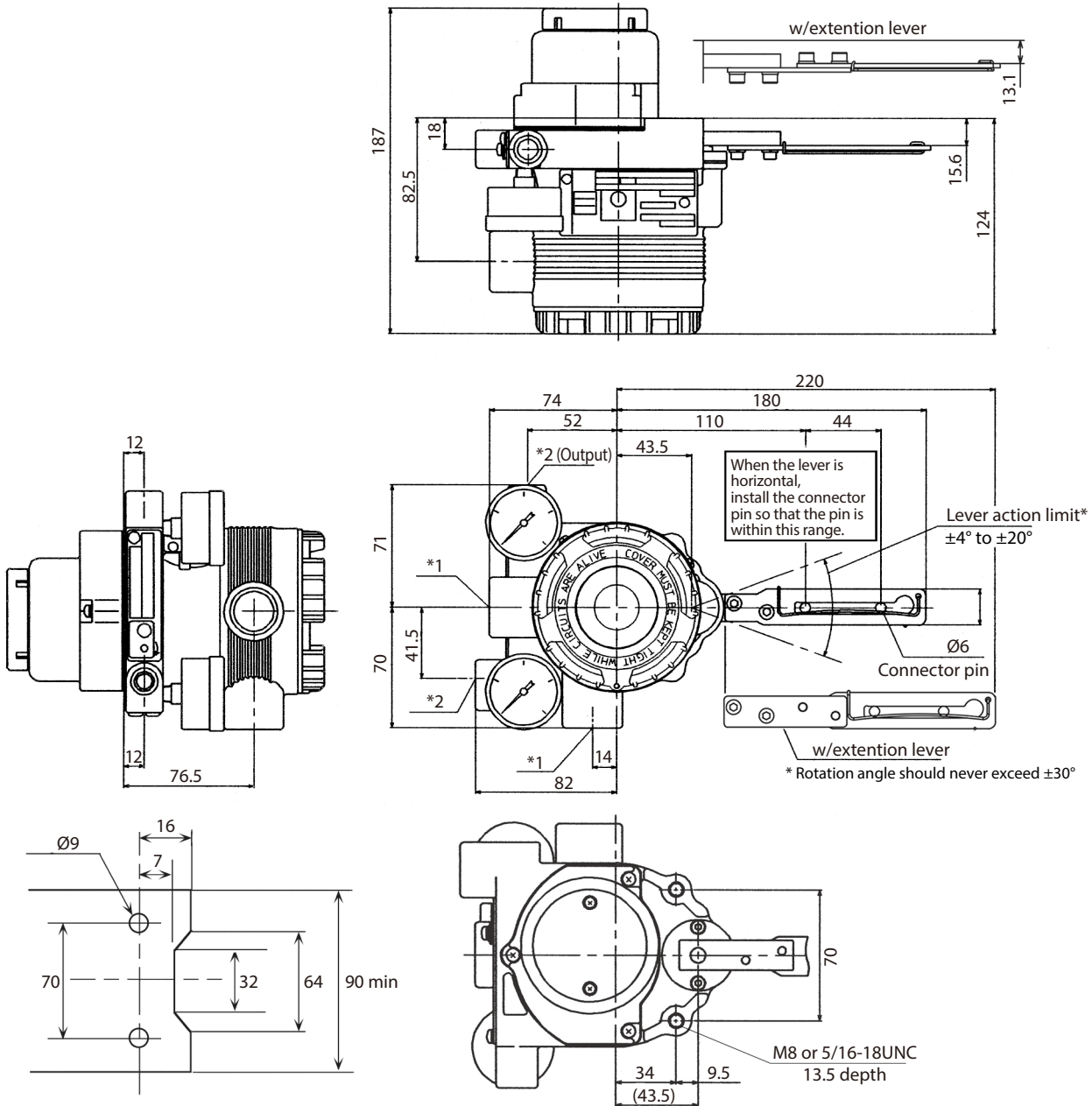

Mounting plate reference dimension

Electrical connection *1	Air piping connection *2
G1/2	Rc1/4
1/2NPT	1/4NPT
M20×1.5	1/4NPT

Terminal connections

Terminal screw size M4

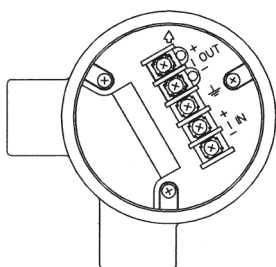

Extension lever	Actuator model	Code
No	PA2, 3	YH
	PSA1, 2, PSK1	YS
	HA1	YA
	HA2, 3	YT
	HK1	YK
Yes	PA4, 5	YQ
	PSA3, 4	
	VA1 to 3	
	PSA6	YL
	PSA7	Y8
	HA4	YN
	VA4 to 6	YL
	VR1	YV
VR2, 3	YR	
GOM83S, 84S, 103S	YG	
GOM124S	YM	



**For double acting actuator with reversing-relay**

[Unit: mm]

**Without pressure regulator**

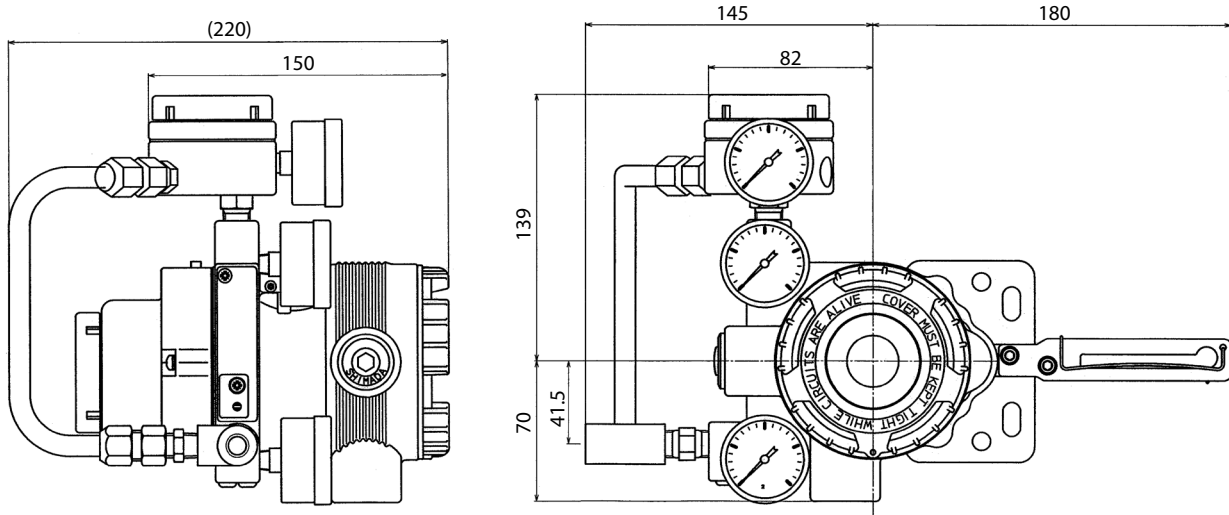

**With pressure regulator model KZ03**

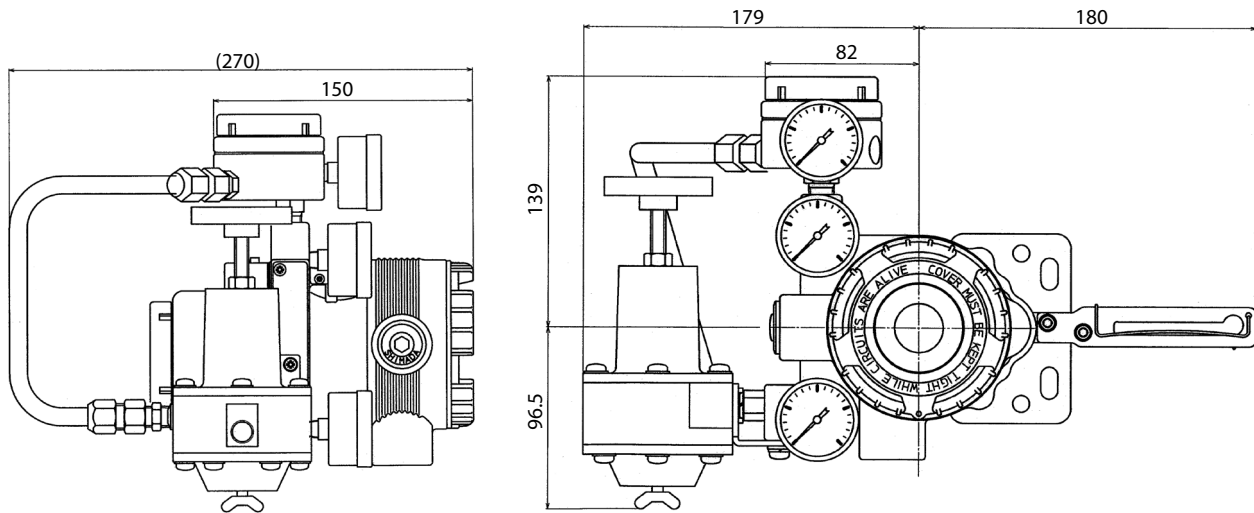







HART® is a registered trademark of FieldComm Group.

Please read "Terms and Conditions" from the following URL  
before ordering and use.

**<https://aa-industrial.azbil.com/jp/en/order>**

*Specifications are subject to change without notice.*

*No part of this publication may be reproduced or duplicated  
without the prior written permission of Azbil Corporation.*

# Azbil Corporation

## Advanced Automation Company

1-12-2 Kawana, Fujisawa  
Kanagawa 251-8522 Japan

For our products and services for factories and plants, please visit:  
URL: <https://aa-industrial.azbil.com/jp/en>

1st edition: Apr. 1998  
42th edition: Feb. 2025