

azbil

Digital Fiber-Optic Switches

Model HPX-EG00/01 : Standard

Model HPX-EG50/51 : Long-distance

Sensing Satisfaction

Freedom from Frequent Adjustments



Please read "Terms and Conditions" from the following URL before ordering and use.
<https://aa-industrial.azbil.com/jp/en/order>

Other product names, model numbers and company names may be trademarks of the respective company.

*[Notice] Specifications are subject to change without notice.
 No part of this publication may be reproduced or duplicated without the prior written permission of Azbil Corporation.*

Azbil Corporation
 Advanced Automation Company

1-12-2 Kawana, Fujisawa
 Kanagawa 251-8522 Japan

URL: <https://aa-industrial.azbil.com/jp/en>

1st Edition: Issued in Mar. 2010-JBA
 7th Edition: Issued in Aug. 2024-SO

Fiber-optic switches that offer **reliable detection** and **simple operation**.

These switches are designed for **ease of use** at the worksite.



Standard models:
HPX-EG00/01

Long-distance models:
HPX-EG50/51

FEATURE of Model HPX-EG00/01
Model HPX-EG50/51

- | | |
|--|----------------------------|
| 01 Hassle-free setting and adjustment | 02 Easy operation |
| 03 Performance | 04 Superior auto-tuning |
| 05 Remote tuning models
(HPX-EG01/HPX-EG51) | 06 Reduced wiring |
| 07 Global standards compliance | 08 Eco-friendly measures |

Long-distance models are now available

In addition to HPX-EG00/01, the long-distance HPX-EG50 and HPX-EG51 models have been added to the lineup. These models can be installed at a distance and used in applications with thin fiber-optic cables.

Standard models	HPX-EG00: Standard distance, standard tuning HPX-EG01: Standard distance, remote tuning
Long-distance models	HPX-EG50: Long-distance, standard tuning HPX-EG51: Long-distance, remote tuning

BASIC OPERATION

- Output indicator**: Points to the left side of the display.
- Preset value**: Points to the left side of the digital display.
- Received light level**: Points to the right side of the digital display.
- + button**: Points to the plus button on the right.
- button**: Points to the minus button on the right.
- Function selection button**: Points to the 'FUNC. CANCEL' button.
- Auto-tuning button**: Points to the 'AUTO OK' button.

Threshold values can be adjusted directly.

Provides an easy-to-understand menu for functions such as the LO/DO switch, key lock, and timer setting.

Just two presses of the button and auto-tuning is complete.

FEATURE of Model HPX-EG00/01 Model HPX-EG50/51



FEATURE 01 Fuss-free adjustment

Auto sensitivity switch function

This function automatically optimizes the sensitivity setting during auto tuning, affording easy operation while delivering the highest detection performance.

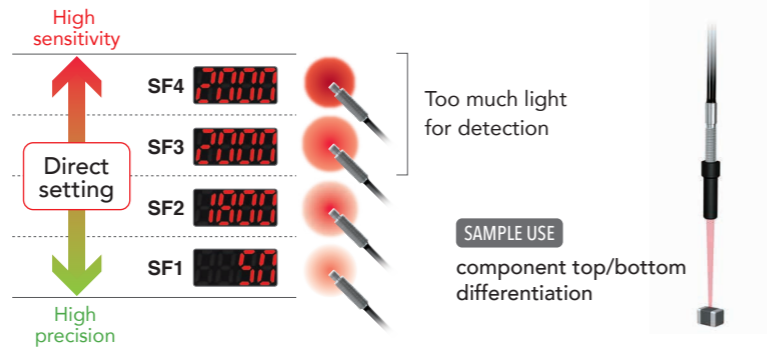

STA (Self Threshold Adjustment) function

This function allows the level of received light to be set as a reference point, enabling the detection threshold to be automatically adjusted by a given ratio in an updating cycle. This ensures the stable detection of target objects, eliminating the effect of fluctuations in the received light level due to environmental changes.

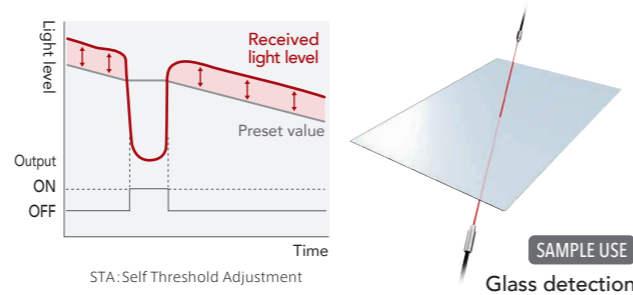

FEATURE 02 Easy operation

Easy-to-understand excess gain indication

The excess gain indication varies from 0% (dark) to 99% (light), with a preset value of 100%. Variations in the received light indication can be eliminated in the same application.

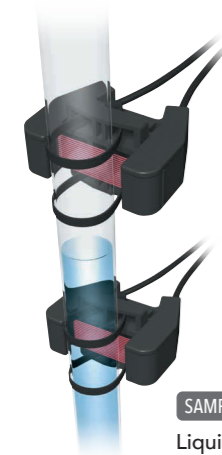

	Absolute value indication		Excess gain indication	
	Preset value	Without liquid	With liquid	With liquid
High high limit sensor	2035	3800	270	P 13
High limit sensor	1874	3500	270	P 13

Note: Formula for excess gain indication: received light level / preset value × 100

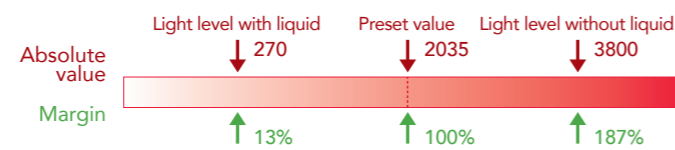

SAMPLE USE Liquid surface detection

FEATURE 03 Performance

Three selectable sensing modes

Three sensing modes can be selected by the desired response speed and sensitivity, according to what is best for your application.

High sensitivity	Sensing mode	Response time	Display maximum
↑	HP (High power)	5ms	9999
	nL (normal)	1ms	9999
	SF (semi-fast)	500μs	9999
↓	FT (fast)	250μs	9999
High speed			

HP (high power) modes are not available on models HPX-EG00 and HPX-EG01.

High accuracy detection

Note: Numerical values assume optimum conditions

Repeatability ± 5μm or less (4σ)	Smallest detectable object: 5μm dia.	Detectable displacement: 20μm
With 1 mm core dia. Model HPF-T003 standard fiber unit	With 1 mm core dia. Model HPF-T003 standard fiber unit	With Model HPF-D034 coaxial fiber unit

FEATURE 04 Superior auto-tuning

Incorporates not only standard 2-point tuning, but also BGS tuning (without a target object), percent tuning and full auto-tuning.

2-point tuning	BGS tuning	Percent tuning
With a target object Without a target object	No target object Background object	No target object
	Setting at the maximum sensitivity that will not detect the background.	For example, set to the desired percent of the value without a target object.

FEATURE **05** Remote tuning models (Model HPX-EG01/HPX-EG51)

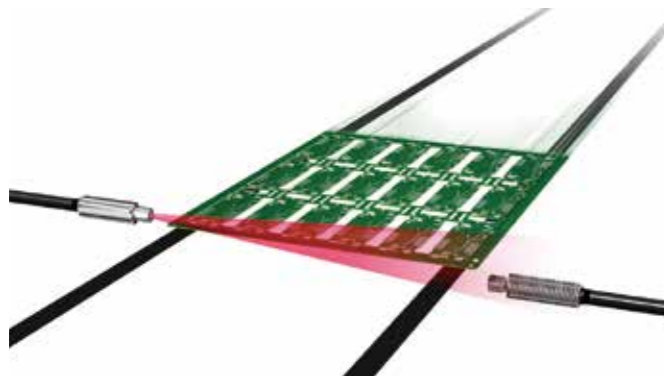

Tuning can be done remotely from a connected device.
Tuning automatically sets the sensor to the optimal sensitivity.

SAMPLE USE
Substrate detection with a rail width change

When there is a change in the rail width or type of substrate, using remote tuning reduces the setup time required.

FEATURE **06** Reduced wiring

Up to 16 units, including a main unit (with power cable) and expansion units (without power cable) can be connected together. It goes without saying that Model HPX-EG can be used in conjunction. Since power to the expansion units is supplied via connectors from the main unit, only a single wire is required for each expansion unit.



Connector

* Only HPX-EG00 and HPX-EG01 offer reduced wiring.

FEATURE **07** Global standards compliance

Models complying with CE and UL standards are available for safe use in export units.

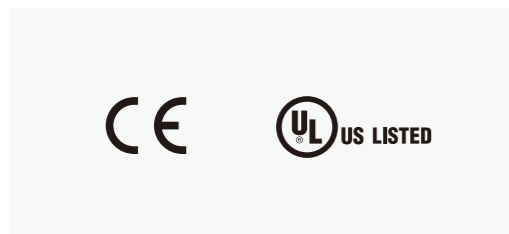

* HPX-EG00 and HPX-EG01 are available for UL standard.

FEATURE **08** Eco-friendly measures

“Shorter cables can do the job” and “Cut cables only end up in the garbage!”
In response to comments like these from our customers, we came to the decision that 1 m cables were sufficient for standard Model HPX-EGs. This reduces the quantity of waste generated, contributing to the protection of our natural environment.

Cable **1 m** (standard)

Model number selection

Model Number selection

Basic model No.	Model	Output	Cord	Features
HPX-EG	00			Standard - Standard Sensitivity -
	01			Remote tuning - Standard Sensitivity -
	50			Standard - High Sensitivity -
	51			Remote tuning - High Sensitivity -
		NPN	PNP	
		-1S	-2S	Cable lead-out
		-3S	-4S	Reduced wiring(main unit) *Standard sensitivity only
		-5S	-6S	Reduced wiring(expansion-unit) *Standard sensitivity only
			(Blank)	1m cable (standard)
			-L02	2m cable
			-L05	5m cable
			-CT	M8 connector

Typical model number example

HPX-EG	51	-2S	-L02
--------	----	-----	------

Amplifier unit accessories

Product name	Appearance	Features / Applications	Model
Dedicated mounting bracket 1 pc		This dedicated bracket can be used instead of a DIN rail to mount a single amplifier. It is not included with the amplifier.	HPX-PA04
End plates 2 pcs		End plates used when mounting on a DIN rail. They are not included with the amplifier.	HPX-PA03

Specifications

Specifications

Model		Standard Sensitivity		High Sensitivity	
Cable lead-out type		HPX-EG0□-1S	HPX-EG0□-2S	HPX-EG5□-1S	HPX-EG5□-2S
Reduced wiring type	Main unit	HPX-EG0□-3S	HPX-EG0□-4S	---	---
	Expansion unit	HPX-EG0□-5S	HPX-EG0□-6S	---	---
Light emitter		Red four-element LED (635nm)		Red four-element LED (660nm)	
Power		12 to 24V DC +10%/-15% (ripple: 10% max.)			
Current consumption		750mW max. (30mA max. at 24 VDC)			
Output type		NPN open collector	PNP open collector	NPN open collector	PNP open collector
Control output	Switching current	Cable lead-out type, M8 connector type : 100mA max.			
	Residual voltage	Reduced wiring type : 50mA max.			
	Output withstand voltage	2V max.	3V max.	2V max.	3V max.
External input	ON (Short circuit current : 0.1mA max.)	0 to 2VDC	7.2 to 26.4VDC	0 to 2VDC	7.2 to 26.4VDC
	OFF	Open or connect to power supply voltage	Open or connect to 0 to 1VDC	Open or connect to power supply voltage	Open or connect to 0 to 1VDC
Response time		250μs(Ft)/500μs(SF)/1ms(nL)		250μs(Ft)/500μs(SF)/1ms(nL)/5ms(HP)	
Mutual interference prevention		2 units (at SF mode, nL mode)			
Expansion unit addition		Up to 15 expansion units can be connected.		---	
Indicator		Output indicator (Turn on with output on)			
Sealing		IP40 (IEC standard)			
Ambient light immunity		Incandescent light : 5,000 lx max. Sunlight : 20,000 lx max.			
Operation temperature		-20 to +55 °C *1			
Operation humidity		35 to 85 %RH (without condensation)			
Vibration resistance		10 to 55 Hz, 1.5mm double amplitude, 2 hours in each direction of X, Y, Z			
Shock resistance		500m/s ² , 3 times in each direction of X, Y, Z			
Protection circuits		False pulse protection (300ms typ.) , Reverse polarity protection			
Case material		Body : PC resin (black) , Cover : PC resin (clear gray)			
Mass (only sensor with cable 1m)		Cable lead-out type(Model HPX-EG0_-1S/-2S) : Approx. 45g Reduced wiring type/main unit(Model HPX-EG0_-3S/-4S) : Approx. 45g Reduced wiring type/expansion units(Model HPX-EG00-5S/-6S) : Approx. 30g Reduced wiring type/expansion units(Model HPX-EG01-5S/-6S) : Approx. 45g		Cable lead-out type(Model HPX-EG5_-1S/-2S) : Approx. 45g	

*1. The temperature varies depending on the number of gang-mounted sensor units as follows.
1 or 2 units : -20 to +55°C ; 3 units : -20 to +50°C ; 4 or 5 units : -20 to +45°C ; 6 units : -20 to +40°C

Input/output

Model	HPX-EG□0-□S	HPX-EG□1-□S
Control output	1 output	1 output
External input	---	1 input

Detailed View of the Operating Panel

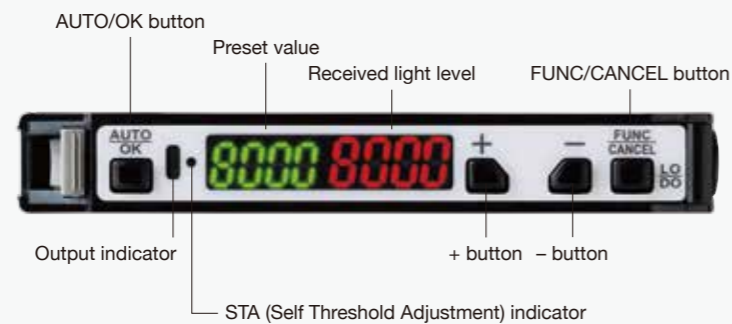

External dimensions

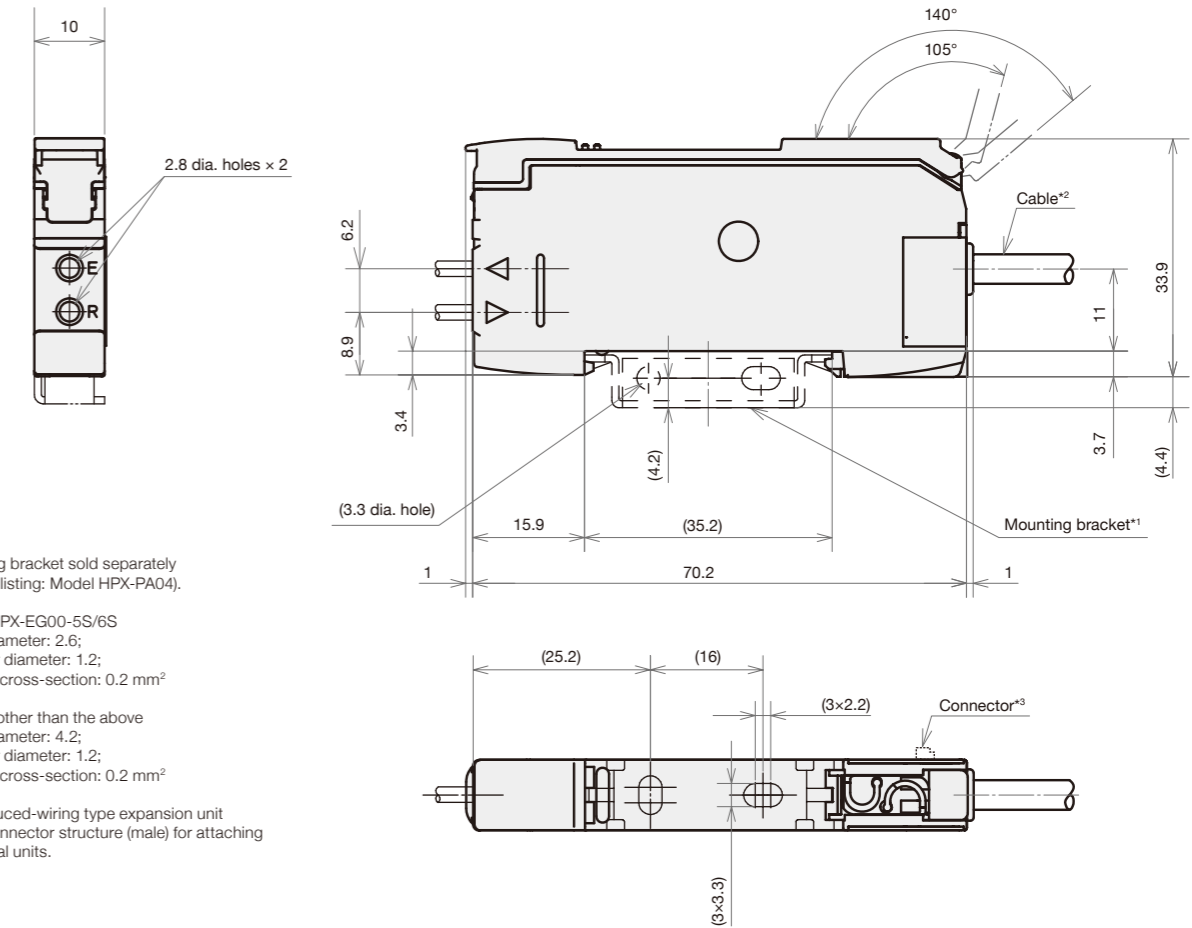

*1. Mounting bracket sold separately (catalog listing: Model HPX-PA04).

*2. Model HPX-EG00-5S/6S
Outer diameter: 2.6;
insulator diameter: 1.2;
nominal cross-section: 0.2 mm²

Models other than the above
Outer diameter: 4.2;
insulator diameter: 1.2;
nominal cross-section: 0.2 mm²

*3. The reduced-wiring type expansion unit has a connector structure (male) for attaching additional units.

Wiring diagram for the amplifier

The output switching device is FET.
Reduced wiring type expansion units are not equipped with a power wires (brown and blue) since power is supplied through the main unit.

Model HPX-EG□0

• NPN open collector output

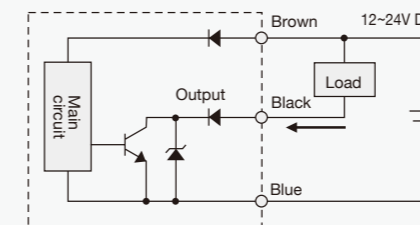

• PNP open collector output

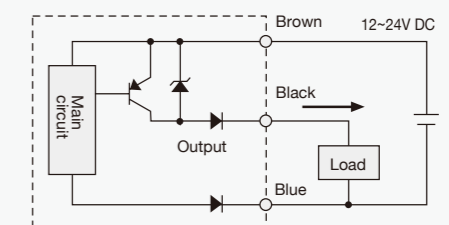

Model HPX-EG□1

• NPN open collector output

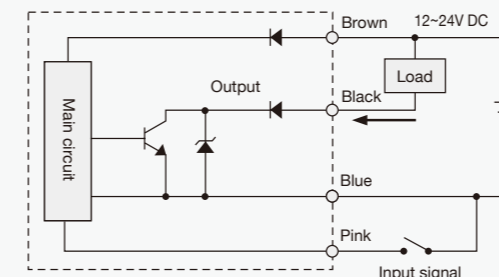

• PNP open collector output

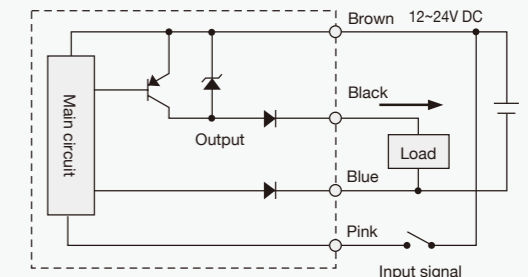

Characteristics of Scanning Distance

Thru scan

Unit : mm						
Standard fiber	Fiber unit (Model No.)	Amplifiers (Model No.)	HP (5ms)	nL (1ms)	SF (500μs)	Ft (250μs)
Standard fiber	HPF-T003	HPX-EG00/01	---	410	350	240
		HPX-EG50/51	940	800	640	350
Unbreakable fiber	HPF-T024	HPX-EG00/01	---	50	42	29
		HPX-EG50/51	110	95	75	41
Heatproof	HPF-T018	HPX-EG00/01	---	210	180	120
		HPX-EG50/51	480	410	320	170
Chemical-proof	HPF-T029	HPX-EG00/01	---	1,500	1,200	880
		HPX-EG50/51	3,500	3,000	2,400	1,300
Area	HPF-T021T	HPX-EG00/01	---	1,200	1,000	710
		HPX-EG50/51	2,800	2,400	1,900	1,000

Diffuse scan

Unit : mm						
Standard fiber	Fiber unit (Model No.)	Amplifiers (Model No.)	HP (5ms)	nL (1ms)	SF (500μs)	Ft (250μs)
Standard fiber	HPF-D002	HPX-EG00/01	---	150	130	90
		HPX-EG50/51	350	300	240	130
Unbreakable fiber	HPF-D029	HPX-EG00/01	---	10	8	5
		HPX-EG50/51	22	19	15	8
Heatproof	HPF-D015	HPX-EG00/01	---	85	70	50
		HPX-EG50/51	160	160	140	75
Chemical-proof	HPF-D014	HPX-EG00/01	---	50	50	50
		HPX-EG50/51	50	50	50	50
Coaxial	HPF-D035	HPX-EG00/01	---	50	42	29
		HPX-EG50/51	95	95	80	43

Operation

Sensing type

Sensing types	Response time	Maximum display value
High Power	5ms	8000
Normal	1ms	4000
Semi Fast	500μs	2000
Fast	250μs	1000

HP (high power) modes are not available on models HPX-EG00 and HPX-EG01.

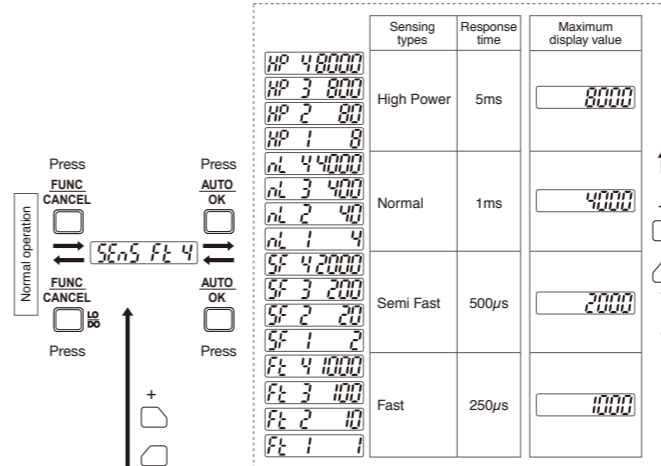

Timer type

Timer types
No timer
On-delay
Off-delay

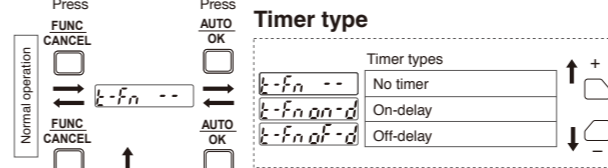

Indication type

Menu	Indication type	Display (green)	Display (red)
d 15P nL	Normal display	Preset value	Incoming light level
d 15P P c nL	Stability safety margin indication	P*	Stability safety margin**

* When the stability safety margin is indicated, "P" is always displayed.
** 余裕度は設定値を100%とした場合の受光量の割合を表示します。

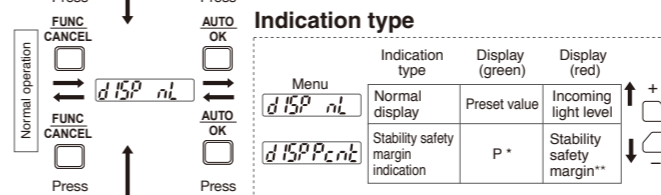

Monitor sleep mode

SLEEP off	Disable monitor sleep
SLEEP on	Enable monitor sleep

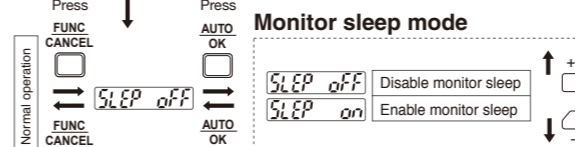

Display inversion

rEw Abcd	Do not invert
ng p q r s	Invert

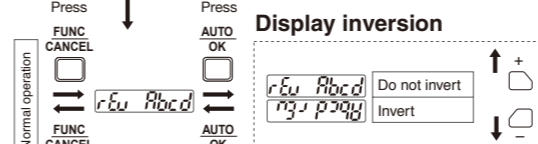

Self Threshold Adjustment (STA)

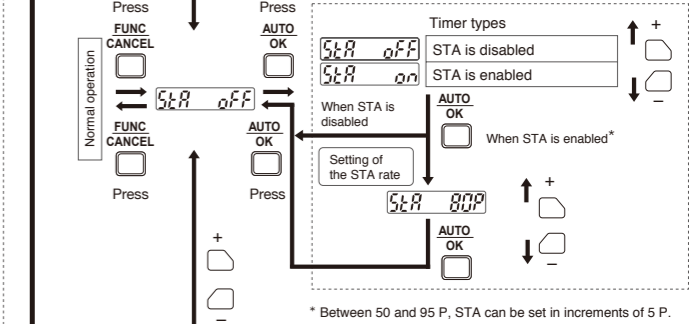

Option

Menu	Automatic sensitivity switching	STA reset upon power-up	EEPROM Storage
Opt Opt 1	<input type="checkbox"/>	<input type="checkbox"/>	<input type="checkbox"/>
Opt Opt 2	<input type="checkbox"/>	<input type="checkbox"/>	<input type="checkbox"/>
Opt Opt 3	<input type="checkbox"/>	<input type="checkbox"/>	<input type="checkbox"/>
Opt Opt 4	<input type="checkbox"/>	<input type="checkbox"/>	<input type="checkbox"/>
Opt Opt 5	<input type="checkbox"/>	<input type="checkbox"/>	<input type="checkbox"/>
Opt Opt 6	<input type="checkbox"/>	<input type="checkbox"/>	<input type="checkbox"/>

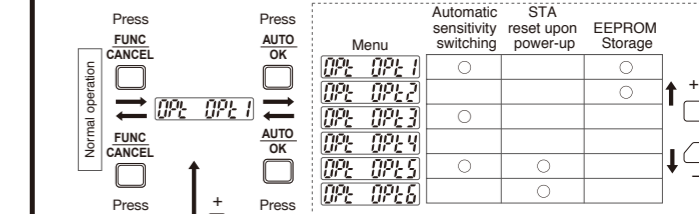

Emitter frequency switching

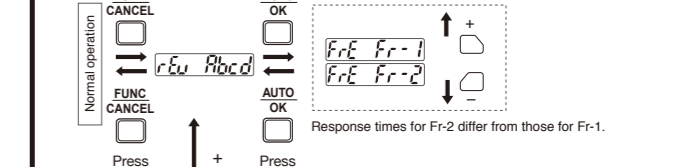

Initialization

