

# AC/DC2-wire Type Cylindrical Proximity Sensors

# FL7M Series

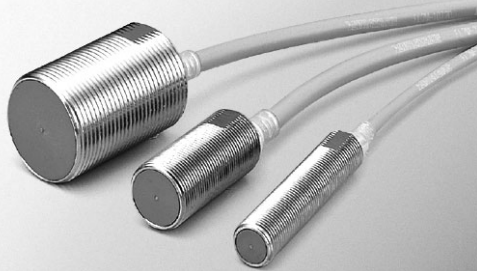



No-polarity 2-wire general-purpose sensors are easy to use.







- 2-wire type for both AC and DC greatly reduces wiring man-hours
- Stable sensing area displayed by setting indicator (green/red LED)
- Indicator lamp can be seen even from the rear (pre-leaded and pre-leaded connector types)
- Compact and space-saving
- Sealed to IP67
- Enhanced circuit protection (surge absorption, load short-circuit)

## ORDER GUIDE



### ● Standard (pre-leaded) type (2m cable)

Exterior		Sensing distance		Operation mode	Setting indicator	Catalog listing
	M12		3mm	N.O.	○	FL7M-3T7HD
	M18		7mm	N.O.	○	FL7M-7T7HD
	M30		10mm	N.O.	○	FL7M-10T7D

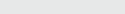

### ● Connector type

Exterior		Sensing distance		Operation mode	Setting indicator	Catalog listing
	M12		3mm	N.O.	○	FL7M-3T7HD-CN
	M18		7mm	N.O.	○	FL7M-7T7HD-CN
	M30		10mm	N.O.	○	FL7M-10T7D-CN

### ● Pre-leaded connector type (30cm cable)

Exterior		Sensing distance		Operation mode	Setting indicator	Catalog listing
	M12		3mm	N.O.	○	FL7M-3T7HD-CN03
	M18		7mm	N.O.	○	FL7M-7T7HD-CN03
	M30		10mm	N.O.	○	FL7M-10T7D-CN03

### ● Accessories (sold separately)

Name	Appearance	O.D.	Catalog listing
Mounting bracket		For M12	FL-PA112
		For M18	FL-PA118
		For M30	FL-PA130
Protective cover		For M12	FL-PA12
		For M18	FL-PA18
		For M30	FL-PA30
Spatter-guarded protective cover		For M08	FL-PA08W
		For M12	FL-PA12W
		For M18	FL-PA18W
		For M30	FL-PA30W

## SPECIFICATIONS

Catalog listing		FL7M-3T7HD(-CN,-CN03)	FL7M-7T7HD(-CN,-CN03)	FL7M-10T7D(-CN,-CN03)
Actuation method		High-frequency oscillation type (shielded)		
Rated sensing distance		3±0.3mm	7±0.7mm	10±1mm
Usable sensing distance		0 to 2.4mm	0 to 5.6mm	0 to 8mm
Standard target object		12×12mm, 1mm thick iron	18×18mm, 1mm thick iron	30×30mm, 1mm thick iron
Differential travel		10% max. of sensing distance		
Rated supply voltage		100/200Vac, 50/60Hz 24Vdc		
Operating voltage range		40 to 250Vac, 20 to 250Vdc		
Leakage current		When AC power supply is used: 2.0mA max. (100/200Vac), When DC power supply is used: 1.1mA max. (24Vdc)		
Control output		Switching current: 5 to 100mA (at 30Vdc supply voltage: 5 to 20mA) Voltage drop: When AC power supply is used 10V max., When DC power supply is used 6V max. Output dielectric strength: 250V (at both AC and DC power supplies)		
Operating frequency		When AC power supply is used 25Hz When AC power supply is used 1KHz	When AC power supply is used 25Hz When AC power supply is used 500Hz	When AC power supply is used 25Hz When AC power supply is used 400Hz
Temperature characteristics		±10% max. for the range of -25 to +70°C when +25°C is taken as standard temperature in sensing distance.		-10 to +60°C
Supply voltage characteristics		±1% max. with +15% voltage fluctuation with rated supply voltage as standard voltage in sensing distance		
Indicator lamps		Operation indication: Lights (red or green) at output Setting indication: Lights (green) in stable sensing area		
Operating temperature range		-25 to +70°C		-10 to +60°C
Storage temperature range		-40 to +85°C		
Insulation resistance		50MΩ min. (at 500Vdc)		
Dielectric strength		4,000Vac, 50/60Hz for 1minute		
Vibration resistance		10 to 55Hz, 1.5mm peak-to-peak amplitude, 2 hrs in X, Y and Z directions		
Shock resistance		980 m/s <sup>2</sup> 10 time in X, Y and Z directions		
Protection		IP67 (IEC standard)		
Weight		Approx. 90g Main unit with 2m pre-leaded cable	Approx. 160g Main unit with 2m pre-leaded cable	Approx. 270g Main unit with 2m pre-leaded cable
Circuit protection		Surge absorption, load short-circuit protection (at 20 to 40Vdc)		
Wiring method		Connector, pre-leaded connector, pre-leaded		
Material	Sensor	Case	Ni-plated brass	
		Sensing face	PBT	
	Connector	Housing	-CN:Ni-plated Zn, -CN03:polyester elastomer	
		Holder	PBT	
		Contact	-CN:Sn-plated brass, -CN03:Gold-plated brass	

## ABOUT SETTING INDICATION

The proximity sensor can detect objects reliably by bringing the proximity sensor close to the target object and setting the sensor at the position where the indicator lamp changes from red to green.

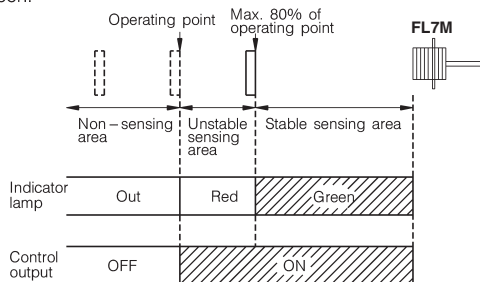

**Note:** When the target object is made of a different material such as aluminum, copper and stainless steel to the standard target object (iron), the setup point where the indicator lamp changes color is shorter than 80% maximum.

## SENSING AREA (typical)

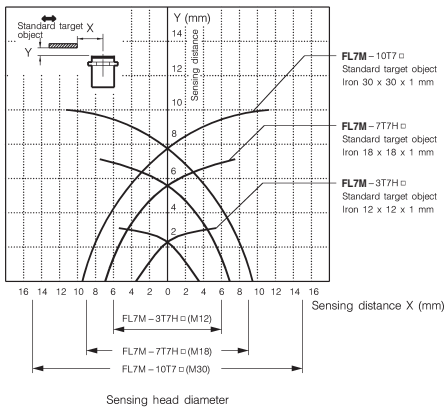

## SENSING DISTANCE ACCORDING TO MATERIAL & SIZE OF OBJECT (typical)

### ● FL7M-3T7H□

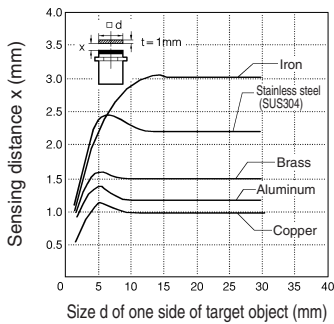

### ● FL7M-7T7H□

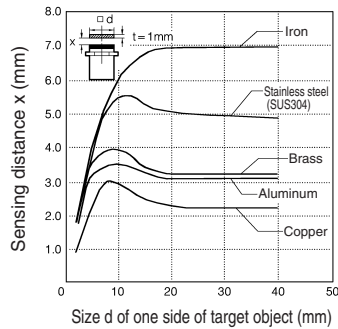

### ● FL7M-10T7□

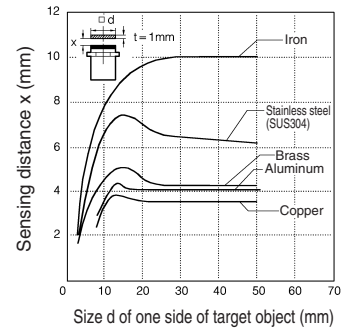

## VOLTAGE DROP (typical)

### ● 24Vdc

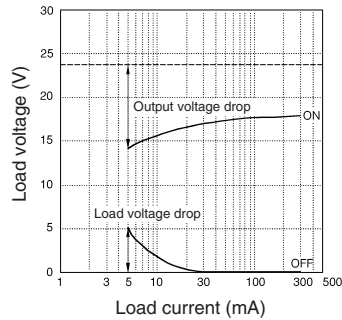
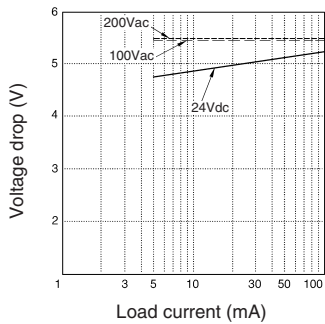

### ● 100Vac

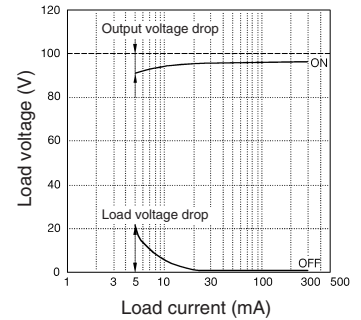

### ● 200Vac

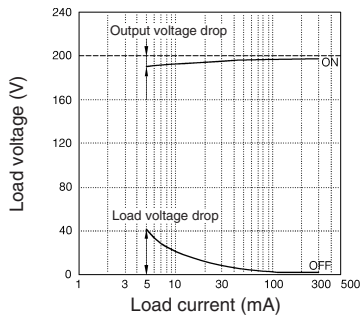

## LEAKAGE CURRENT (typical)

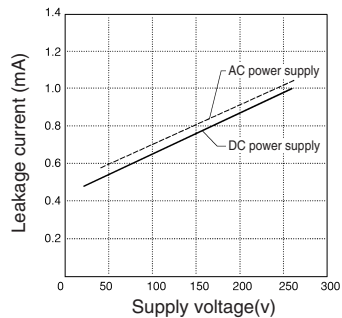

**Standard (prelead) type**

**FL7M-3T7HD**

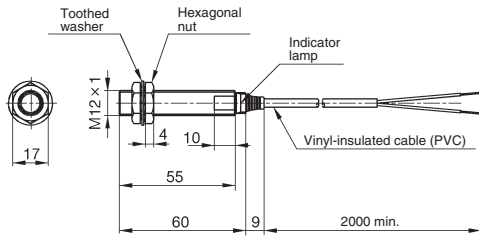

Vinyl-insulated cable (oil-resistant: 0.3mm<sup>2</sup>, 60/0.08, 2-core)  
dia. 4. Cap color: orange.

**FL7M-7T7HD**

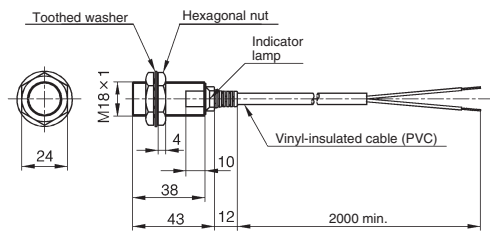

Vinyl-insulated cable (oil-resistant: 0.5mm<sup>2</sup>, 45/0.12, 2-core)  
dia. 6. Cap color: orange.

**FL7M-10T7D**

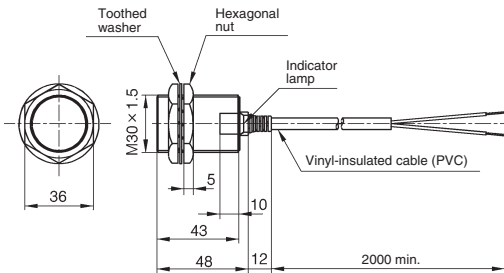

Vinyl-insulated cable (oil-resistant: 0.5mm<sup>2</sup>, 45/0.12, 2-core)  
dia. 6. Cap color: orange.

**Connector type**

**FL7M-3T7H□-CN**

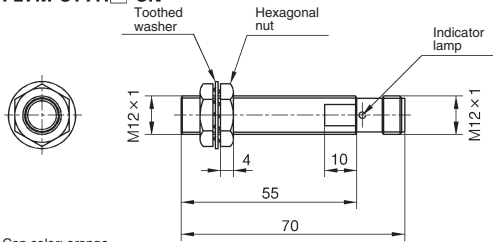

Cap color: orange.

**FL7M-7T7H□-CN**

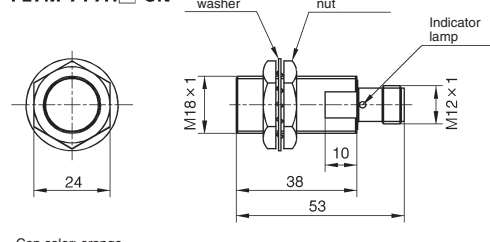

Cap color: orange.

**FL7M-10T7□-CN**

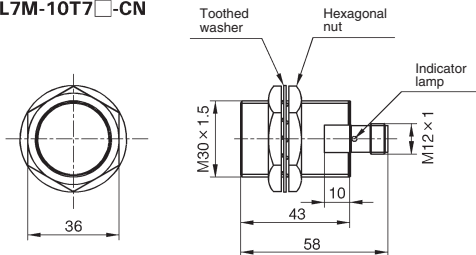

Cap color: orange.

Note:

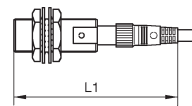

When using a straight-type connector, dimension L1 is the overall length plus about 30mm.

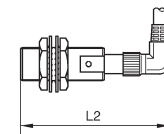

When using an angled connector, dimension L2 is the overall length plus 20mm.

## ● Prelead connector type

### FL7M-3T7H□-CN03

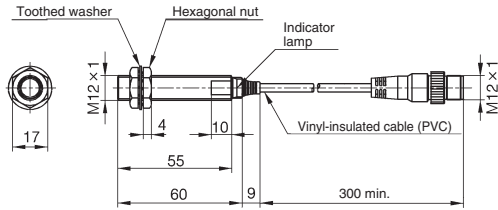

Vinyl-insulated cable (oil-resistant: 0.3mm<sup>2</sup>, 60/0.08, 2-core)  
dia. 4. Cap color: orange.

### FL7M-10T7□-CN03

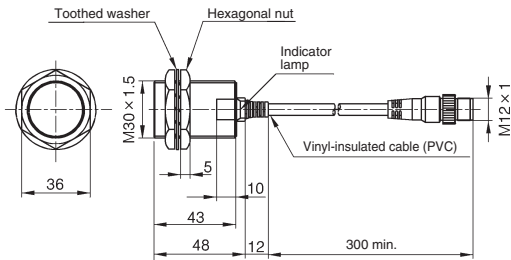

Vinyl-insulated cable (oil-resistant: 0.5mm<sup>2</sup>, 45/0.12, 2-core)  
dia. 6. Cap color: orange.

### FL7M-7T7H□-CN03

(unit: mm)

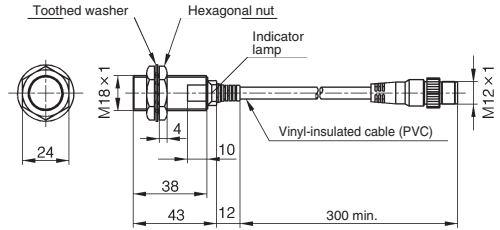

Vinyl-insulated cable (oil-resistant: 0.5mm<sup>2</sup>, 45/0.12, 2-core)  
dia. 6. Cap color: orange.

## ■ MOUNTING BRACKET (sold separately)

Mounting brackets are made of polyacetal resin.  
Two screws and two washers are provided for each bracket.

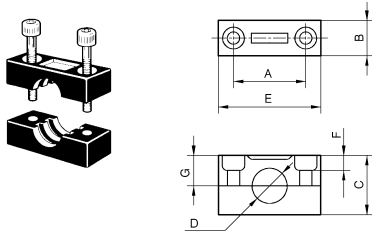

FL-PA118 and FL-PA130 screw holes are oblong.

Catalog listing	Dimensions (mm)							Screw size	
	A	B	C	D	E	F	G	Dia.	Neck
FL-PA112	25	12	20	12dia.	36	6	9.5	M4	25
FL-PA118	30/32	15	30	18dia.	45	7.5	14.5	M5	35
FL-PA130	40/45	15	50	30dia.	60	10	24.5	M5	55

### Allowable tightening torque of bracket screws

Catalog listing	Max. torque (N·m)
FL-PA112	0.98
FL-PA118	1.5
FL-PA130	1.5

## ■ PROTECTIVE COVER (sold separately)

Protective covers made of polyacetal resin are available for shielded models. Select a model according to the sensor's external dimensions.

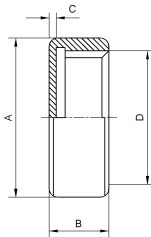

Catalog listing	Dimensions (mm)			
	A	B	C	D
FL-PA12	14dia.	5	0.5	M12x1
FL-PA18	21dia.	6	0.5	M18x1
FL-PA30	33dia.	8	1.5	M30x1.5

## SPATTER-GUARDED PROTECTIVE COVER (sold separately)

Spatter-guarded protective covers made of fluorine resin and designed especially for shielded sensors are available. Select a model according to the sensor's external dimensions.

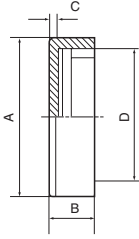

Catalog listing	Dimensions (mm)			
	A	B	C	D
FL-PA08W	10dia.	5	0.5	M8x1
FL-PA12W	15dia.	5	0.7	M12x1
FL-PA18W	22dia.	6	0.7	M18x1
FL-PA30W	34dia.	8	1.5	M30x1.5

## WIRING DIAGRAMS

### Preleaded type

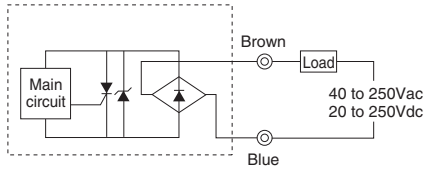

### Preleaded connector type

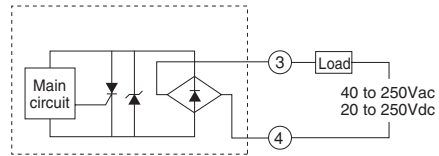

- The load may be connected to either pole.
- The LED operates normally during a load short circuit, so check the wiring if the output is wrong.
- Fasten connectors tightly by hand.

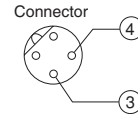

## CONNECTOR SPECIFICATIONS<sup>1</sup>

Item	Specifications
Insulation resistance	Max. 100MΩ (by 500Vdc megger)
Dielectric strength	1,500Vac for 1 minute (between contacts, and between contact and connector housing)
Initial contact resistance	Max. 40mΩ (with 3A current to connected male and female connectors. Semiconductor lead-specific resistance not included.)
Mating/unmating force	0.4 to 4.0 N per contact
Mating cycles	50
Connector nut tightening torque	Min. 0.8N·m <sup>2</sup>
Cable pullout strength	Min. 100 N
Vibration resistance	10 to 55Hz, 1.5mm peak-to-peak amplitude, for 2 hours each in X, Y and Z directions
Impact resistance	300m/s <sup>2</sup> , 3 times each in X, Y and Z directions
Protective structure	IP67
Ambient operating temperature	-10 to +70°C
Ambient storage temperature	-20 to +80°C
Ambient operating humidity	Max. 95% RH
Material Contacts:	Gold-plated brass Contact holder: Glass-lined polyester resin Housing: Polyester elastomer Coupling: Ni-plated brass O-ring: NBR

Note 1: Specifications assume Yamatake male/female connectors.

Note 2: The recommended torque is 0.4 to 0.6N·m. If fastened poorly, the IP67 protection is lost, or looseness occurs. Fasten the connector securely by hand.

## CABLE WITH CONNECTOR

Be sure to use **PA5 Series** cables with connector to connect preleaded type connectors and connector type limit switches.

### ● PA5 Series cable with connector

Shape	Power supply	Cable properties	Cable length	Catalog listing	Lead colors
	AC/DC	Oil-resistant, flexible; UL2464; flame-resistant; EN-compliant	2m	PA5-4JSX2MK-E	1: brown, 2: white, 3: blue, 4: black
			5m	PA5-4JSX5MK-E	1: brown, 2: white, 3: blue, 4: black
			2m	PA5-4JLX2MK-E	1: brown, 2: white, 3: blue, 4: black
			5m	PA5-4JLX5MK-E	1: brown, 2: white, 3: blue, 4: black

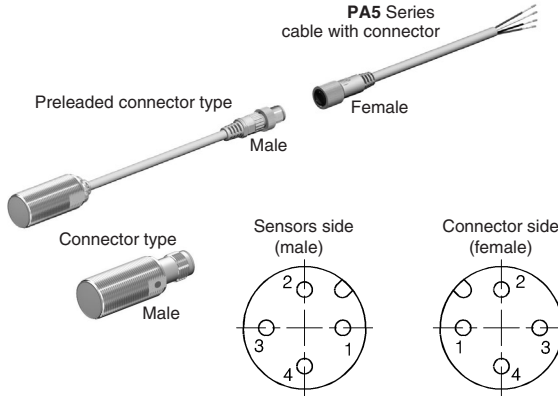

### ● Tightening the connector

Align the grooves and rotate the fastening nut on the **PA5** connector by hand until it fits tightly with the connector on the sensors side.

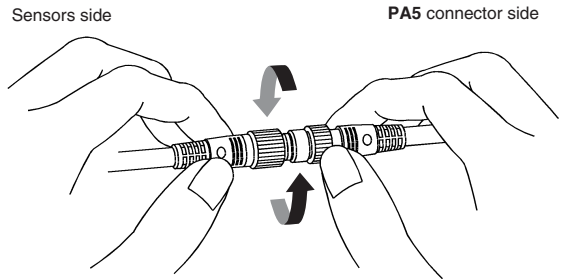

## PRECAUTIONS FOR USE

### 1. Mounting

Catalog listing	Max. tightening torque (N·m)
FL7M-3T7H□	20
FL7M-7T7H□	70
FL7M-10T7□	180

Note: The table shows the allowable tightening torque when toothed washers (provided) are used.

### 2. Influence of surrounding metal

Metal other than the target object surrounding the sensor may influence operating characteristics. Leave space between the sensor and surrounding metal as shown below. Shaded areas indicate surrounding metal other than the target object.

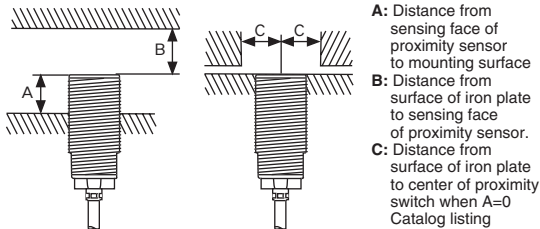

Catalog listing	A(mm)	B(mm)	C(mm)
FL7M-3T7H□	0	8	9
FL7M-7T7H□	0	20	13.5
FL7M-10T7□	0	40	22.5

### 3. Mutual interference prevention

When mounting proximity sensors either parallel to or facing each other, mutual interference may cause the sensor to malfunction. Maintain at least the distances indicated in the figures below.

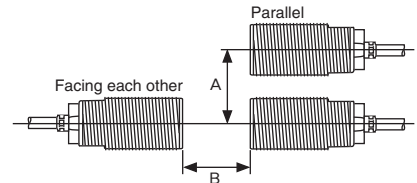

Catalog listing	A(mm)	B(mm)
FL7M-3T7H□	20	30
FL7M-7T7H□	35	50
FL7M-10T7□	70	100

## 4. Cautions for series or parallel connection

### 4.1 Series connection (AND switching circuit)

In case of either 100Vac or 200Vac, the voltage which is applied to the load in the ON condition is  $V_L = V_S - (\text{output voltage drop} \times \text{number of units}) (V)$ . Note that the load will not be activated unless  $V_L$  is more than the minimum activating voltage of the load.

When more than 2 units are connected in series and are used in an AND switching circuit, the maximum number of units is 3. (Pay attention to the  $V_S$  value shown in the figure below.)

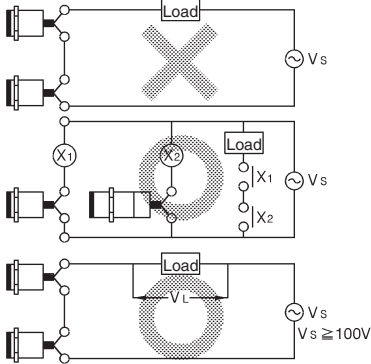

### 4.2 Parallel connection (OR switching circuit)

In principle it is not possible to use more than 2 proximity sensors in parallel as an OR switching circuit. A parallel connection can be used only if A and B do not operate at the same time and if it is not necessary to hold the load. However, consumption current (leakage current) will be multiplied by  $n$  (the number of proximity sensors), and recovery failure will occur more easily.

If A and B operate at the same time and if it is necessary to retain the load, a parallel connection cannot be used. Under these conditions, when A is turned ON, the voltage at both ends of A and B drops to approx. 10V, allowing load current to flow through A. When a target object approaches B, the switching element of B cannot be activated because the voltage at both ends of B is too low. When A is again turned OFF, the voltage at both ends of A and B increases to the power supply voltage, and at this point B can be turned ON for the first time.

During this time, since there is a period (approx. 10ms) when both A and B are OFF, the load is momentarily reset. In order to retain the load, use a relay as shown below.

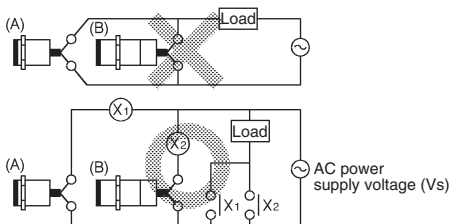

## 5. Loads that cause inrush current

When the proximity sensor is connected to a load such as an electromagnetic switch, lamp or motor that causes inrush current, use the sensor within the rated current, which includes the inrush current.

## 6. Connection to power supply and load

Be sure to connect the proximity sensor to the power supply via the load. If the sensor is connected directly to the power supply, the sensor will be damaged. Also, output does not have polarity, so the load can be connected to either side of the power supply. However, we recommend connecting the load to the non-grounded side to prevent short-circuiting of the power supply if a ground fault caused by damage to the proximity sensor occurs.

## 7. Operation upon power ON

After the power is turned ON, it takes at most 80ms until the proximity sensor is ready for sensing. If the load and the proximity sensor use different power supplies, be sure to turn the proximity sensor ON before turning the load ON.

## 8. Influence of leakage current

A minimal current flows as leakage current for operating the circuits even when the proximity sensor is OFF. Keep this in mind when turning off connected loads.

## 9. Minimum cable bend radius (R)

The minimum bend radius (R) of the cable is 3 times the cable diameter. Take care not to bend the cable beyond this radius. Also, do not excessively bend the cable within 30mm of the cable lead-in port.